

Maintenance Manual

On-Line UPS Single Phase

1KVA/2KVA/3KVA
Standard Models

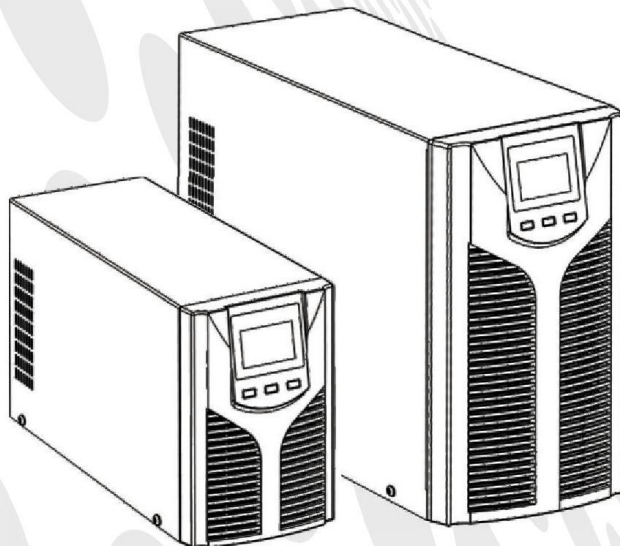

Introduction

Overview

For the maintenance needs of high-frequency 1-3KVA UPS, this manual is developed from various aspects including maintenance safety precautions, product introduction, internal structure introduction, PCB construction, PCB main components, main functions, troubleshooting procedure, PCB replacement, PCB maintenance and commissioning after maintenance, etc. to help engineers to carry out technical support and maintenance works on this product.

Readers

This document (the manual) is mainly applicable to following engineers:

Technical support engineers

Maintenance engineers

Revision Record

The revision record accumulates the description of each document update. The latest version of the document contains updates to all previous versions of the document.

The document of version V01 (2021-04-13) was officially issued for the first time.

Contents

1 Safety Precautions	1
1.1 Hazardous Matters.....	1
1.2 Warnings.....	1
2 Product Introduction	2
2.1 HF 1-3K Series UPS Introduction.....	2
2.2 HF 1-3K UPS Rear Panel (Tower Type).....	3
2.3 HF 1-3K UPS Alarms and LCD Display Functions.....	3
3 Internal Structure Instruction	8
3.1 Working Principle.....	8
3.1.1 Working Principle.....	8
3.1.2 Operating Mode.....	8
3.2 Block Diagram for Components of High Frequency UPS.....	9
3.3 High Frequency 1-3K UPS Main Circuit Topology.....	10
3.4 High Frequency 1-3K UPS Internal PCBs.....	12
4 Troubleshooting	18
4.1 Maintenance Tools List.....	18
4.2 Troubleshooting Procedure.....	19
4.3 Fault Message Collection.....	20
4.3.1 LCD Panel Alarm Message Collection.....	20
4.3.2 Network Management Alarm Message Collection.....	21
4.4 Common Faults and Handling Methods.....	21
4.5 Fault Codes Explanation and Handling Suggestions.....	22
5 PCB Replacement	25
6 PCB Maintenance & Modular Maintenance	26
6.1 REC&PFC Power Components Maintenance.....	26
6.2 INV Power Components Maintenance.....	27
6.3 DC/DC Power Components Maintenance.....	28
6.4 CHGR Charger Board Maintenance.....	29
7 Commissioning After Maintenance	33
7.1 PCB Installation.....	33
7.2 Inspection After Installation.....	33
7.3 Drive Test.....	33

7.3 Power-on Commissioning.....	35
8 Appendix: Wiring Diagram.....	37

1 Safety Precaution

1.1 Hazardous Matters

1. There will be dangerous voltage generated inside the UPS and the battery box, so only the professional engineers with professional electrician qualifications and authorization can carry out installation and maintenance.
2. Operation and maintenance personnel as well as professional technicians shall be subject to sufficient training on safe use and maintenance, and shall operate the product with adequate precautions and personal protective equipment.
3. UPS is connected to a battery, so even if it is not connected to the mains, there may still be a voltage present at its output end.
4. When the UPS is needed to be moved or rewired, it must be firstly turned off and then the connection to the mains shall be cut off. After the UPS is completely turned off, disconnect the battery input and press the left-most setting key for 3 seconds to discharge the battery. Please do not perform relevant operations until the UPS is completely powered off (more than 2 minutes), otherwise the input and output terminals may still have voltage.
5. To ensure personal safety and the normal use of UPS, the UPS shall be reliably grounded before use.
6. When maintaining the UPS, the maintainers must wear insulated shoes and use the tools with insulating treatment.
7. Do not operate the device if the temperature and humidity of the installation environment exceed the limits specified in the user manual.
8. Before maintenance, the maintainer shall disconnect all UPS input (battery input included) and output.
9. It is strictly prohibited to put the battery in fire, so as to prevent explosion that will endanger personal safety.
10. Do not disable protective devices and ignore the warnings, cautions and precautions on the manual and device nameplate.

1.2 Warnings

1. Do not open or damage the battery cover; if you touch the electrolyte by accident, rinse immediately with plenty of water and go to the hospital for medical check.
2. When operating the battery, remove watch, ring and other metal objects, and wear insulated gloves and use the tool with an insulated handle.
3. When the UPS is working, it is necessary to ensure that all internal and external fixtures are secure.

2 Product Introduction

2.1 HF 1-3K Series UPS Introduction

This series UPS are divided into tower types and RT types, which come in 1KVA, 2KVA and 3KVA. With an output power factor of 0.9, they provide a stable and reliable power supply for customers.

Table 2-1 High Frequency 1-3K Series UPS Main Unit Types

Unit	Models	Specifications	Remarks
UPS	1KS	1KS Tower Type	Built-in 24V/9AH or 36V/7AH battery
UPS	2KS	2KS Tower Type	Built-in 48V/9AH or 72V/7AH battery
UPS	3KS	3KS Tower Type	Built-in 72V/9AH or 96V/7AH battery
UPS	1KS	1KSRT	Built-in 24V/9AH or 36V/7AH battery
UPS	2KS	2KSRT	Built-in 48V/9AH or 72V/7AH battery
UPS	3KS	3KSRT	Built-in 72V/9AH

Table 2-2 High Frequency 1-3K Series UPS Accessories

Unit	Models	Specifications	Remarks
Monitoring System	SNMP card		Realize Ethernet network monitoring for multiple UPSs
	Dry contact interface card	AS400	Realize detection of system monitoring switch value, including: UPS normal and remote shutdown, bypass mode, low battery voltage, UPS malfunction
	RS232		Realize background monitoring for single UPS
	USB		Realize background monitoring for single UPS
	UPSmart monitoring software CD	UPSmart	In collaboration with RS232/USB card to realize monitoring for UPS



Figure 2-1 1KS DC24&DC36V/ 2KS DC48V

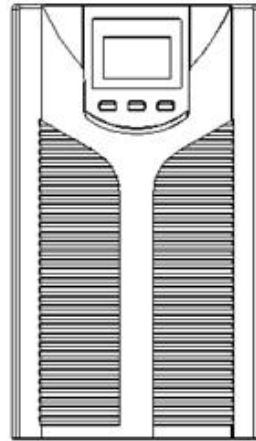

Figure 2-2 2KS DC72V/ 3KS DC72V&DC96V

2.2 HF 1-3K UPS Rear Panel (Tower Type)

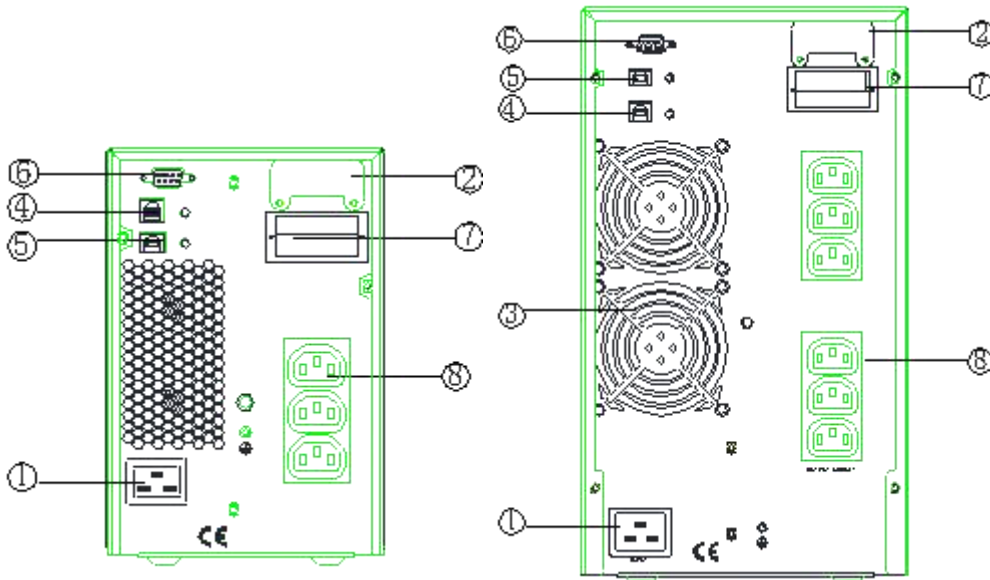

Figure 2-3 1KS DC24&DC36V/ 2KS DC48V

Figure 2-4 2KS DC72V/ 3KS DC72V&DC96V

① AC input socket	⑥ RS232 port
② Battery connector	⑦ Intelligent slot
③ Fan	⑧ Output sockets
④ USB port	
⑤ EPO (Emergency Power Off) port	

2.3 HF 1-3K UPS Alarms and LCD Display Functions

Displays and alarms under various operating states

Operating state	LCD display	Audible alarm	LCD blink
-----------------	-------------	---------------	-----------

Mains inverter mode			
Normal mains voltage	Operating mode area displays Line	None	None
High/low mains voltage protection, switch to battery	Operating mode area displays bAT	Sounding every 4 seconds	Sounding every 4 seconds
Battery mode			
Normal battery voltage	Operating mode area displays bAT	Sounding every 4 seconds	Sounding every 4 seconds
Abnormal battery voltage alarm	Operating mode area displays bAT, battery symbol blinks	Sounding every second	Sounding every second
Bypass mode			
Normal mains voltage (under bypass mode)	Operating mode area displays byPASS	Sounding every 2 seconds	None
Battery disconnection alarm			
Under bypass condition	Operating mode area displays byPASS, battery symbol shows '0' and keeps blinking	Sounding every 4 seconds	Blinking every 4 seconds
Under inverter condition	Operating mode area displays Line, battery symbol shows '0' and keeps blinking	Sounding every 4 seconds	Blinking every 4 seconds
Power on or start up	As connected to the mains, LCD lights up and the power section shows the capacity of the device; after a period of time, the operating mode area displays Line or byPASS and the battery symbol keeps blinking	Sounding 6 times	In steady light
Output overload protection			
Overload under mains mode, in alarming	Operating mode area displays Line, and the load symbol keeps blinking	Sounding twice every second	Blinking twice every second
Overload under mains mode, with protection action	Operating mode area displays FAULT and corresponding codes	Long beep	In steady light
Overload under battery mode, in alarming	Operating mode area displays bAT, and the load symbol keeps blinking	Sounding twice every second	Blinking twice every second

Overload under battery mode, with protection action	Operating mode area displays FAULT and corresponding codes	Long beep	In steady light
Bypass overload alarm	Operating mode area displays byPASS, and the load symbol keeps blinking	Sounding every 2 seconds	Blinking every 2 seconds
Fan fault (fan icon blinks)	The fan icon blinks and the operating mode area displays according to current mode	Sounding every 2 seconds	None
Fault mode	The operating mode area displays FAULT and numeric area displays corresponding fault codes	Long beep	In steady light

Notes: Provide following information when you contact the service personnel:

- ◇UPS model (MODEL NO.), and UPS serial number (SERIAL NO.);
- ◇Problem occurrence date;
- ◇Complete description about the problem (including all kinds of LCD display status, buzzer sounds, power, load capacity)

Alarm Codes Corresponding Table

When there is any alarm, alarm codes will appear on the LCD, and they are displayed by the four digital tubes at the right side of the numerical display area, as shown below:

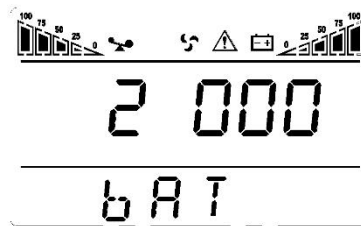

The truth table for alarms that appear during operation of the UPS is shown as below: ‘●’ indicates there is alarm occurred and ‘blank’ indicates there is no alarm.

The first digital tube counted from right to left	Displayed value	Bypass lost	Remote shutdown	Overload	Battery disconnected
	0				
	1	●			
	2		●		
	3	●	●		
	4			●	

	5	•		•	
	6		•	•	
	7	•	•	•	
	8				•
	9	•			•
	A		•		•
	B	•	•		•
	C			•	•
	D	•		•	•
	E		•	•	•
	F	•	•	•	•
The second digital tube counted from right to left	Displayed value	Over charge alarm	Mains inversion	Abnormal start	Charger malfunction
	0				
	1	•			
	2		•		
	3	•	•		
	4			•	
	5	•		•	
	6		•	•	
	7	•	•	•	
	8				•
	9	•			•
	A		•		•
	B	•	•		•
	C			•	•
	D	•		•	•
	E		•	•	•
	F	•	•	•	•
The third digital tube counted from right to left	Displayed value	EEG3AM abnormal	Fan abnormal	Low battery voltage	Sampling mid-value abnormal
	0				
	1	•			
	2		•		
	3	•	•		
	4			•	
	5	•		•	
	6		•	•	
	7	•	•	•	

	8				•
	9	•			•
	A		•		•
	B	•	•		•
	C			•	•
	D	•		•	•
	E		•	•	•
	F	•	•	•	•
The fourth digital tube counted from right to left	Displayed value	Overload fault	Mains lost	Bypass abnormal	
	0				
	1	•			
	2		•		
	3	•	•		
	4			•	
	5	•		•	
	6		•	•	
	7	•	•	•	

Example: Alarm code “2000” is shown on the LCD, indicating that the mains power is lost.

3 Internal Structure Instruction

3.1 Working Principle

3.1.1 Working Principle

High Frequency 1-3K UPS working principle block diagram as figure 3-1 shown:

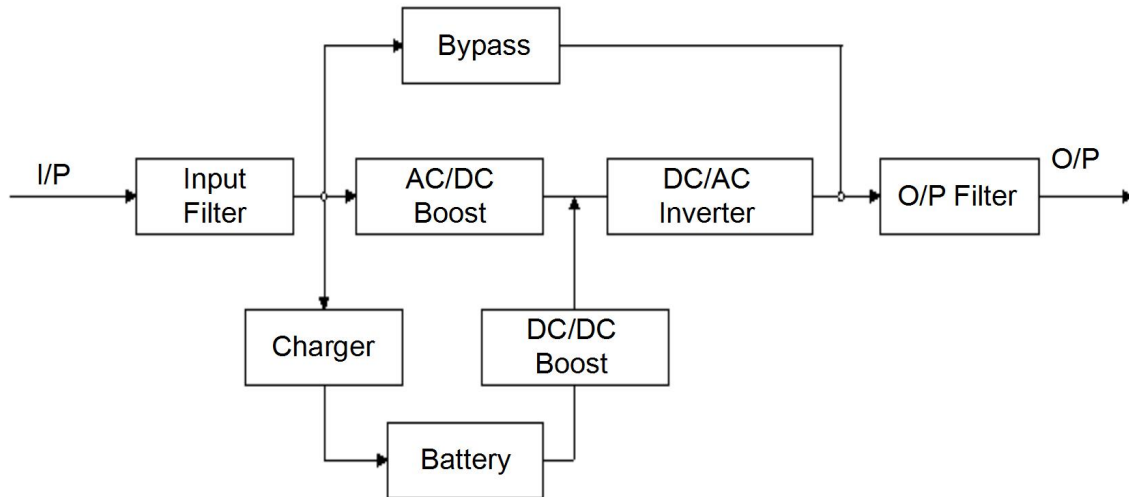

Figure 3-1 High frequency 1-3K UPS working principle block diagram

3.1.2 Operating mode

Main operating modes of the high frequency 1-3K UPS include: mains mode, battery mode, bypass mode, ECO mode, frequency conversion mode, fault mode.

> Mains Mode

In case of normal mains, the mains input is transformed through a filter to stable DC bus voltage that is supplied to the inverter, meanwhile the battery is charged by the mains via a charger. The inverter will output stable AC power to drive the loads.

> Battery Mode

In the event of abnormal mains or mains interruption, the battery will supply power to the inverter through a DC/DC transformer and the inverter will output stable AC power to drive the loads.

> Bypass Mode

The mains supplies power directly to the loads through a filter; in bypass mode, if the input voltage and frequency are within the bypass setting range, the UPS will supply power to the loads via bypass, and if the input voltage and frequency are beyond the bypass setting range, it will transfer to standby mode; in case of overload, over-temperature or malfunction, the UPS will automatically switch the loads to bypass. This mode has no battery backup capability.

> ECO Mode

In ECO mode, if the input voltage and frequency are within the ECO setting range, the UPS will supply power to the loads via bypass, and if the input voltage and frequency are beyond the ECO setting range, it will transfer to mains inverter or battery inverter mode.

> Frequency Conversion Mode

In this mode, the output frequency does not change with the input frequency, but it will be fixed at 50Hz or 60Hz (through setting on the panel).

> Fault Mode

In the event of faults, the UPS enters the fault mode and the buzzer beeps for a long time. For example, when overload, inverter fault, over-temperature or other faults occur, the UPS will transfer to bypass output or switch off output and the LCD displays fault codes; at this point, you can not only press the mute button to temporarily mute the buzzer waiting for maintenance, but also press the combined shutdown key to shut down the UPS after confirming there are no serious faults.

3.2 Block Diagram for Components of High Frequency 1-3K UPS

High Frequency 1-3K UPS block diagram for components as below:

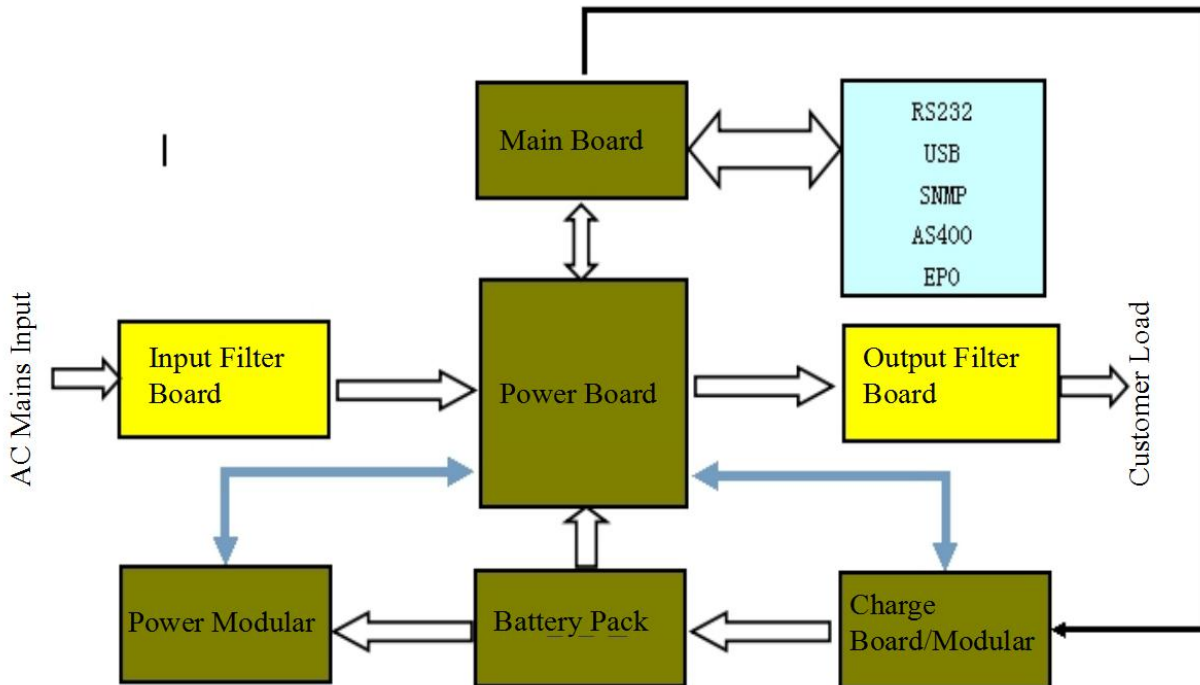

Figure 3-2 Block Diagram for Components of High Frequency 1-3K UPS

3.3 High Frequency 1-3K UPS Main Circuit Topology

The main circuit topology of high frequency 1-3K UPS is shown as below:

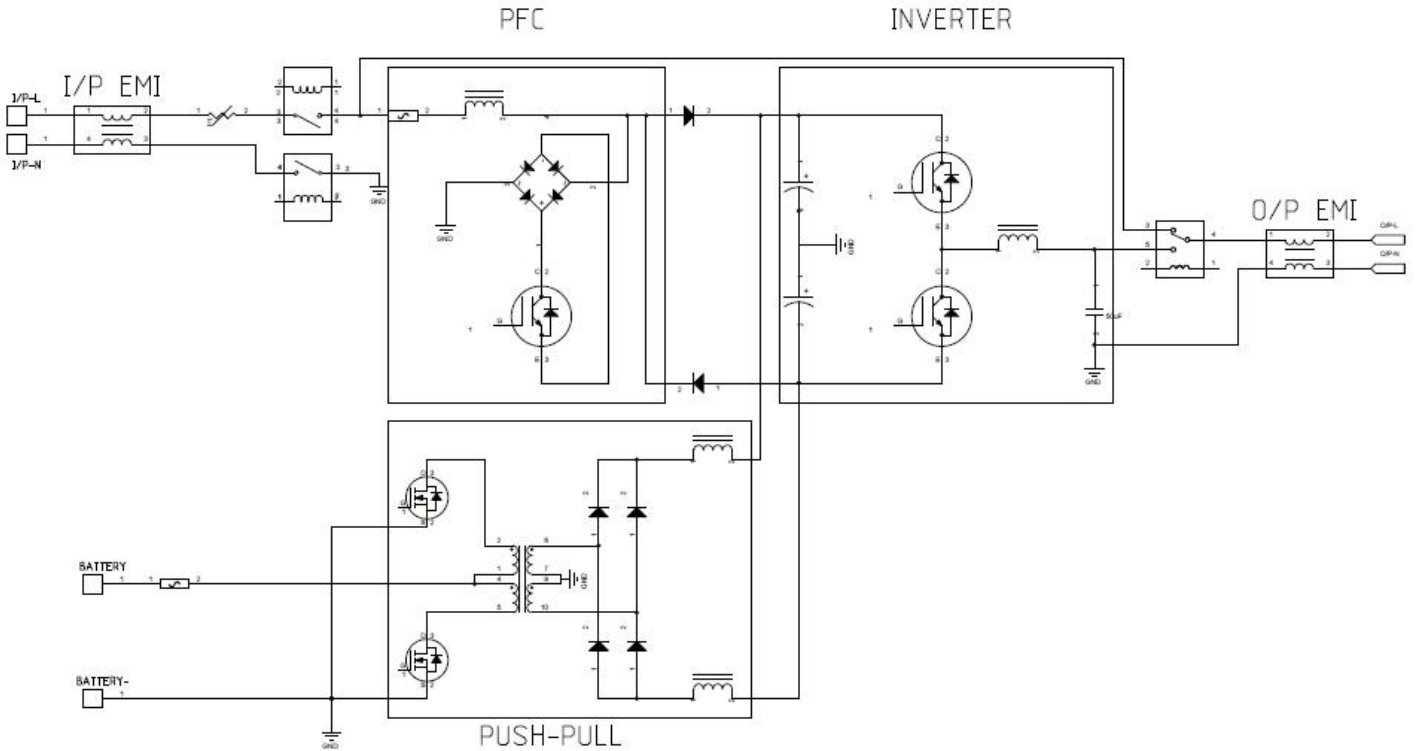

Figure 3-3 High Frequency 1-3K UPS Main Circuit Topology

Main Circuit and Working Principle Description:

As shown in the electrical schematic diagram, AC-DC PFC boost is performed based on Vienna topology, DC-AC dual-level half-bridge inversion is applied, battery DC-DC adopts push-pull boost, power board and charge board employ single-tube kickback.

When the mains input is normal, bus voltage will be generated via PFC boost circuit and converted to AC voltage via DC/AC inverter circuit to supply the loads.

When the mains input is abnormal (beyond UPS mains input range or power outage), the battery supplies the bus with DC voltage via DC boost circuit and the DC voltage will be converted to AC voltage through the inverter.

When faults occur inside the UPS, it will be switched to bypass mode without interruption to continuously supply power to the loads. (Except for output short circuit)

When the input power cord is connected to the mains, since the inverter inlay is normally closed, the mains input L enters the bypass main line via IP_EMI filter board and then output via inverter inlay and OP_EMI filter board. (Bypass mode is on)

While the input power cord is connected to the mains, the mains input L/N enters power board via FUSE and filter. Then, the power board starts to work, and main control board, display board, etc. establish work power, and the UPS enters bypass mode.

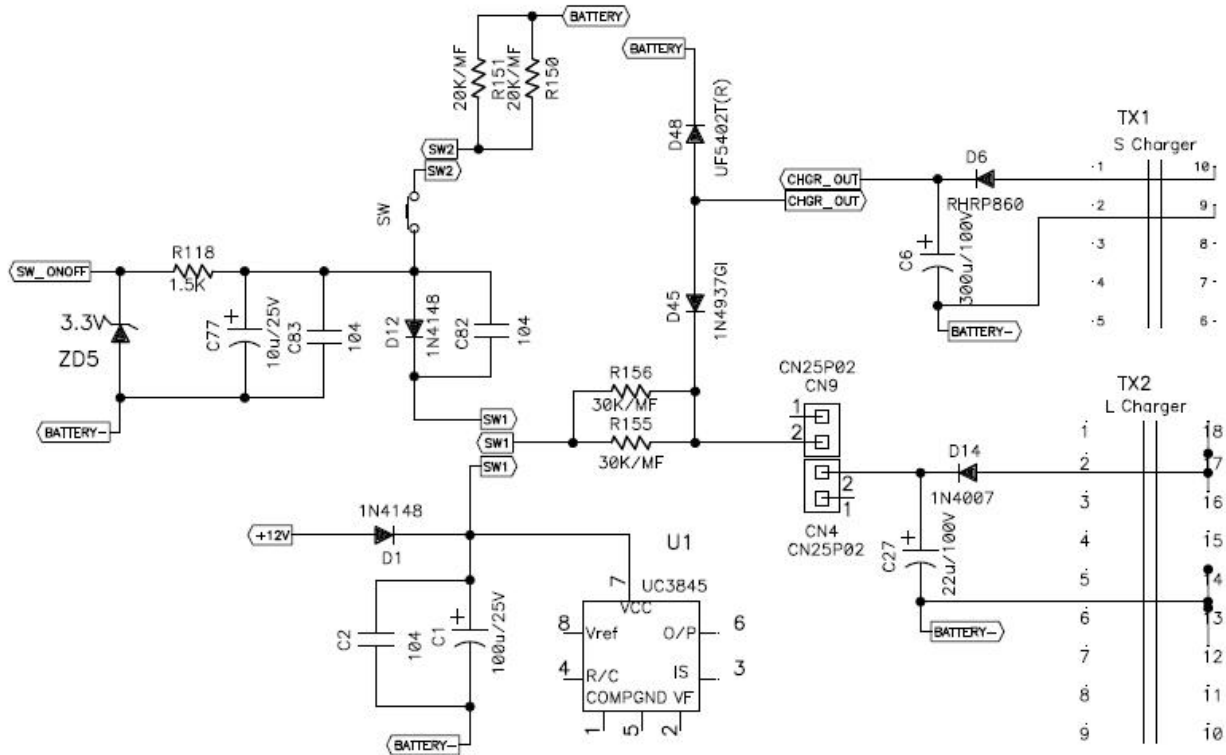

Figure 3-4 High Frequency 1-3K UPS Power-On Circuit Schematic Diagram

(Parameters in the figure are used for reference only, be subject to the parameters in BOM)

Power-on Process:

1. Battery Mode

1) Power is not turned on. The UPS does not work.

2) Power is turned on. SW switch is closed, the battery supplies the SPS chip UC3845 with start-up power, SPS system power module circuit starts to work and produces power for system work, and system working power supply is built. When ON button pressing action is detected by the CPU, soft start process begins, generating drive signal for switch MOS tubes in push-pull circuit. Through the push-pull circuit, battery voltage is converted to BUS voltage via a DC/DC converter. BUS voltage soft start is achieved through feedback regulation. When the BUS voltage rises gradually and stabilizes at 350Vdc, the BUS voltage soft start finishes. Then the inverter voltage soft start begins. CPU sends INV IGBT SPWM drive signal which forms a sine wave through inverter filter circuit on the power board, and at the same time a standard sine wave is obtained by feedback regulation to detected inverter voltage and inverter current. When the inverter voltage gradually rises to 220Vac, inverter voltage soft start finishes. The O/P RELAY jumps to the inverter end, and the UPS has output.

2. Mains Mode

1) Power is not turned on when there is normal AC input. Charger module CHGR starts to work, supplying the SPS chip UC3845 with start-up power. SPS system power module circuit starts to work

and produces power for system work, and system working power supply is built. The CPU performs following operations according to software settings to bypass (Defaulted is that UPS comes with bypass): (Power-on timing is different in UPS with or without bypass)

A. Without Bypass. The CPU turns off AC-DC rectifier boost circuit, DC-DC boost circuit and DC-AC inverter circuit, and the UPS has no output and is in standby mode. After the Power ON button is pressed, CPU turns on the DC-DC boost circuit. When the BUS voltage rises to 360V after soft start, the inverter voltage soft start begins; when the inverter voltage reaches 220V, O/P RELAY switches from BYPASS to INV output and I/P RELAY is opened. AC-DC rectifier boost circuit starts to work and the DC-DC boost circuit is turned off. The UPS works in mains mode.

B. With Bypass. CPU generates drive signal for switch MOS tubes in push-pull circuit. Through the push-pull circuit, battery voltage is converted to BUS voltage via a DC/DC converter. When the BUS voltage rises to approximately 350Vdc, I/P RELAY is opened and the UPS enters bypass mode. After the Power ON button is pressed, CPU turns on the AC-DC rectifier boost circuit and turns off DC-DC boost circuit. When the BUS voltage rises to 360V after soft start, the inverter voltage soft start begins; when the inverter voltage reaches 220V, O/P RELAY switches from BYPASS to INV output.

2) Mains Mode and Battery Mode Conversion

A. Mains mode → Battery mode. When the mains input is interrupted or abnormal, CPU turns off the I/P RELAY and AC-DC rectifier boost circuit and turns on DC-DC boost circuit. The UPS works in battery mode.

B. Battery mode → mains mode. When the mains input recovers, CPU firstly turns on I/P RELAY and AC-DC rectifier boost circuit, and after a period of time turns off DC-DC boost circuit. The UPS switches to mains mode.

3.4 High Frequency 1-3K UPS Internal PCBs

Table 3-1 High Frequency 1-3K UPS Internal PCB Functions

No	PCB name	PCBA codes	PCB description	Functions	QTY	Remarks
1	1KS power board DC24V	12-196700-00	1KS Tower type RT in common	Input EMI, SPS, CHGR, main power	1	Power board include input EMI, SPS, CHGR, main power functions
2	2KS power board DC48V	12-196100-00	2KS Tower type RT in common	Input & output EMI, SPS, CHGR, main power	1	Power board include input & output EMI, SPS, CHGR, main power functions
3	3KSRT power board DC72V	12-190400-00	3KSRT	Input & output EMI, SPS, CHGR, main power	1	Power board include input & output EMI, SPS, CHGR, main power functions
4	3KS Tower type power board	12-120500-00	3KS Tower type	Input & output EMI, SPS, CHGR, main	1	Power board include input & output EMI, SPS, CHGR, main

	DC72V			power		power functions
5	Main control board	12-059900-05			1	Suitable for 1-3K UPS
6	LCD display board	20-006649-00	RT type display screen	1. Execute communication with the main control board and provide real-time monitoring of UPS status. 2. Provide HMI for UPS monitoring.	1	Suitable for RT type, with two LED lights
7	LCD display board	20-007267-00	Tower type display screen	1. Execute communication with the main control board and provide real-time monitoring of UPS status. 2. Provide HMI for UPS monitoring.	1	Suitable for Tower type, with two LED lights
8	RS232 communication board	12-007800-00	RS232 communication interface board	Provide RS232 communication interface; Realize monitoring of single set of UPS.	1	Suitable for whole types; RS232 communication board standard
9	USB communication board	12-092000-00	USB communication interface board	Provide USB communication interface; Realize monitoring of single set of UPS.	1	Suitable for whole types; USB communication board optional
10	SNMP card	90-022085-00	Network communication card	Provide Ethernet network communication solution for users.	1	Suitable for whole types; Optional card
11	AS400 card	90-031002-00	Dry contact card	Realize detection of system monitoring switch value and expansion of control, and control signals comprise	1	

				relevant dry contact alarm signals, mainly including: UPS normal, bypass mode, low battery voltage, UPS malfunction		
--	--	--	--	---	--	--

	<p>CNTL main control board</p>
	<p>1KS power board</p>

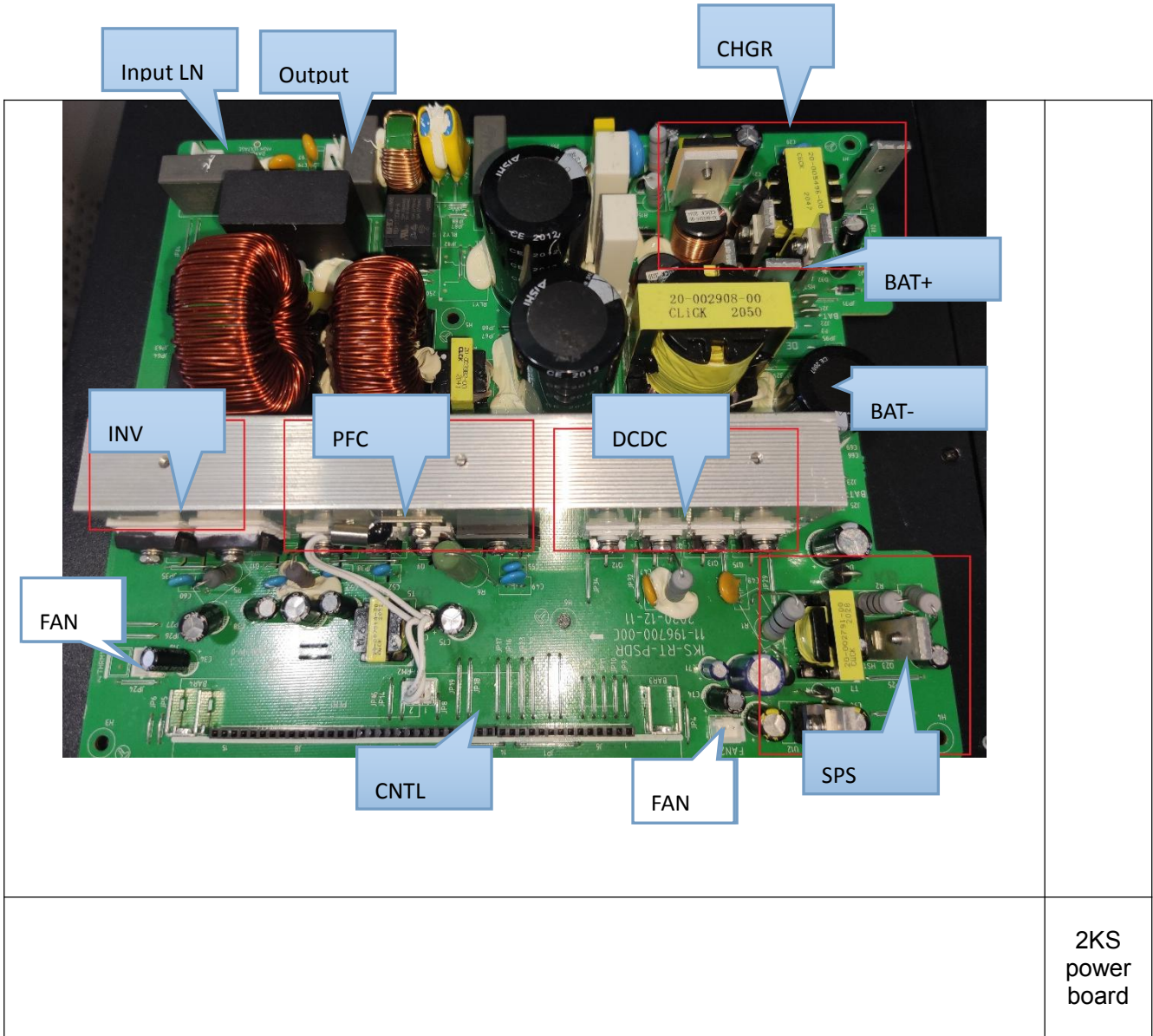

2KS
power
board

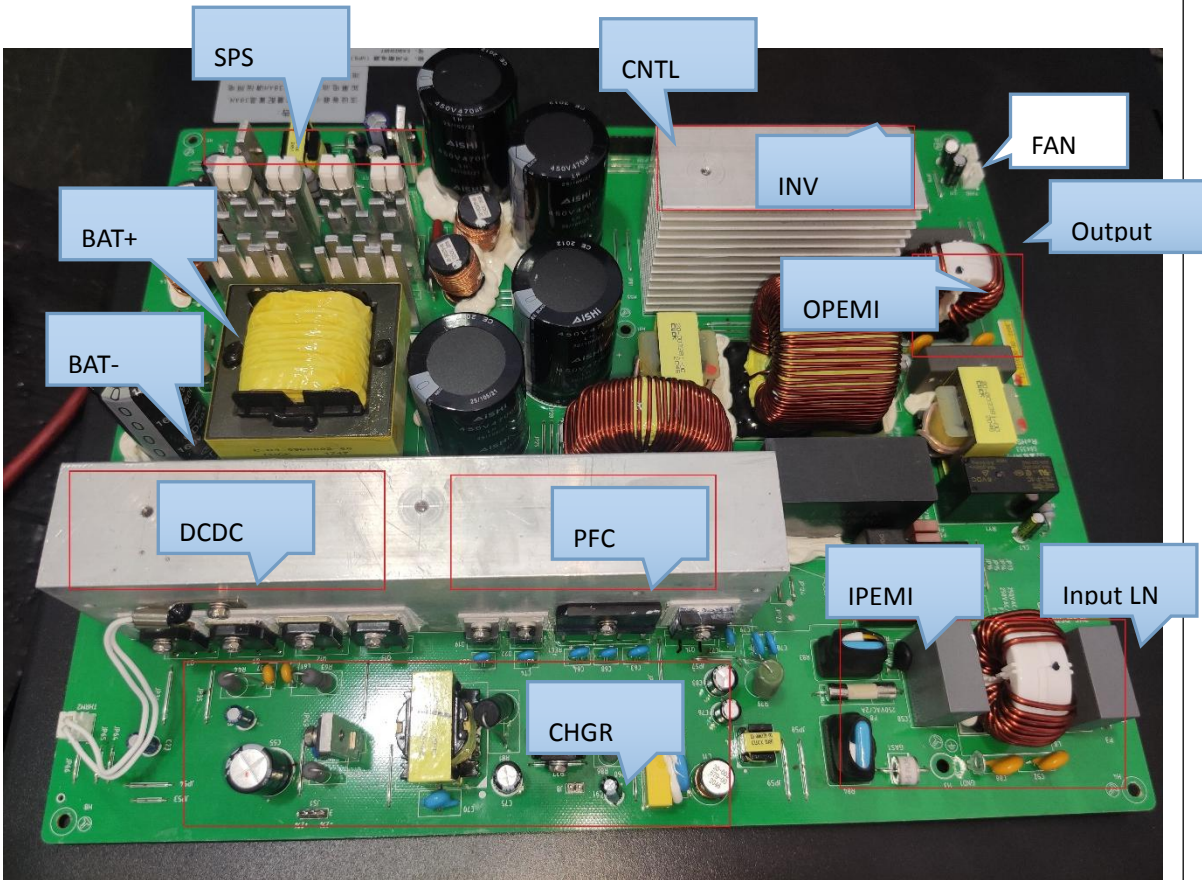
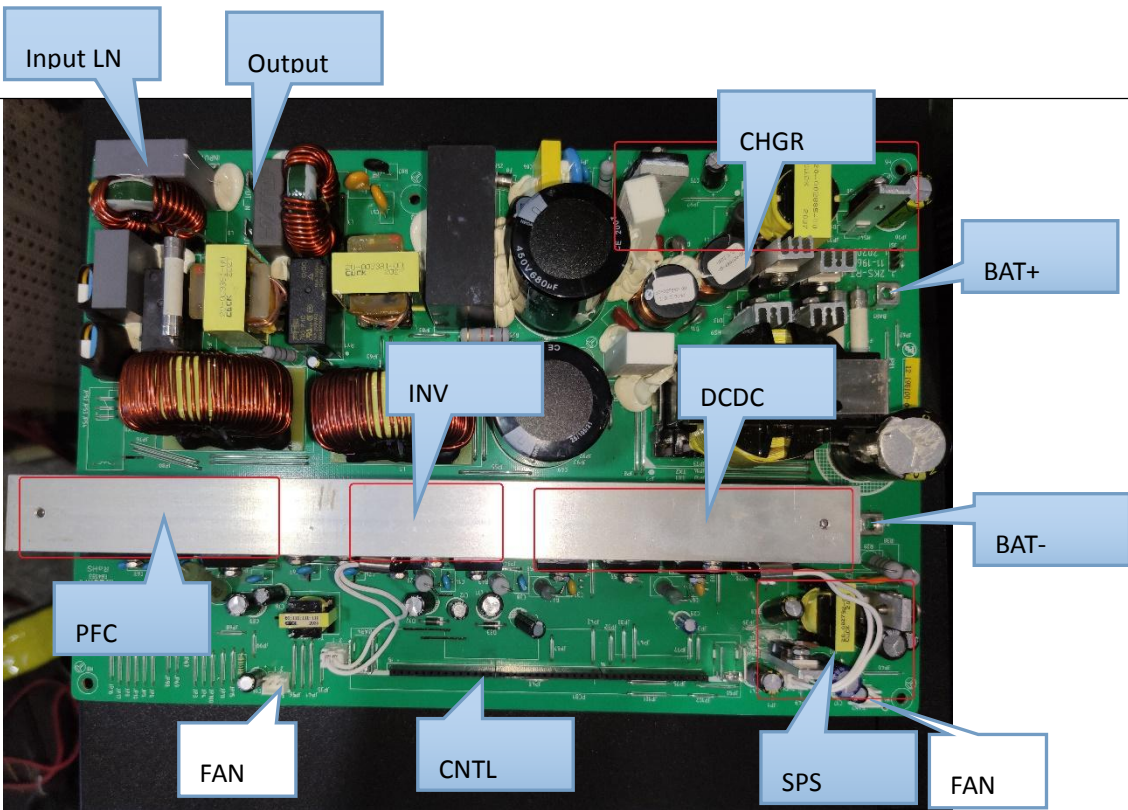

3KS Tower type power board

	<p>3KS RT power board</p>
	<p>Tower type LCD display board</p>
	<p>RT LCD display board</p>

Figure 3-5 High Frequency 1-3K UPS Internal PCBs

4 Troubleshooting

This section mainly introduces the alarm information of the system, meaning of the alarms, the possible causes of the alarm and the handling methods.

4.1 Maintenance Tools List

Table 4-1 Maintenance Tools List

Required Tools	QTY	Remarks
Oscilloscope	1	Measure relevant waveform
Multimeter	1	Measure voltage and resistance etc.
High voltage isolation probe	Several	Measure voltage signal
DC power source	1	Provide limited DC power supply
AC power source	1	Provide limited AC power supply
Screwdriver, sharp-nose pliers, diagonal pliers, etc.	1 kit	Used for assembly and disassembly of UPS and PCB
Soldering iron, solder wire, etc.	1 kit	Used for soldering
Loads	1	Used after UPS maintenance and commissioning

4.2 Troubleshooting Procedure

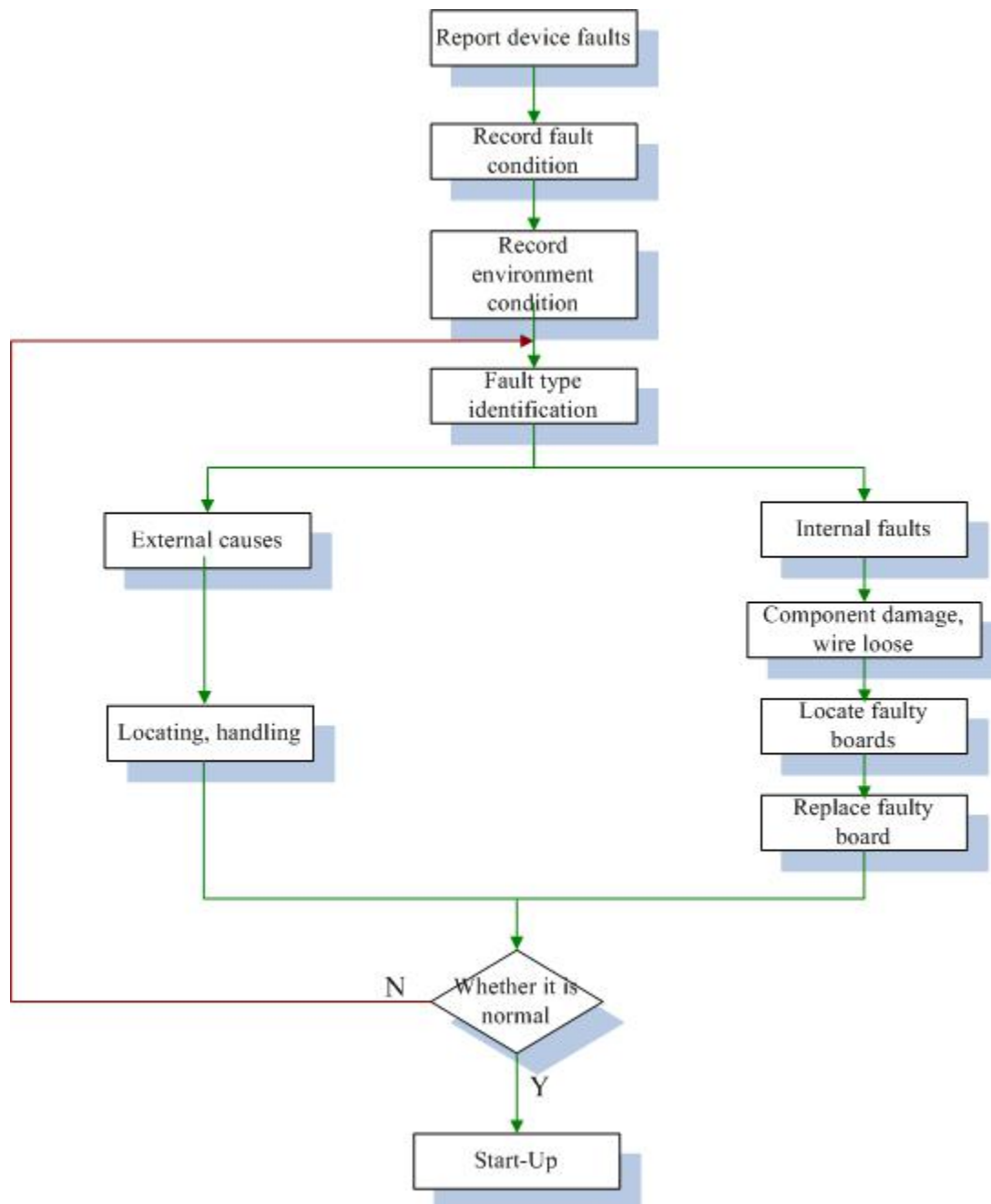

Figure 4-1 Troubleshooting Procedure Chart

1. In-situ Faults Record: The in-situ data of faults is of great importance. Based on the data, fault points and causes can be probably determined and thereby right solutions can be developed. So the first thing that service engineer needs to do when arriving at the in-situ is to record all the conditions of the power system, mainly including:

1) Power system status (Panel and monitoring information): Display interface of the LCD screen and the status of the UPS on the network management side;

2) Power system actual input, output and battery parameters: When faults occur, the parameters displayed on the panel are not always the real parameters of the UPS. You can use a multimeter to

measure the actual parameters on the terminals and make records, including: input voltage, output voltage, battery voltage;

3) Positions of various switches of power system;

4) Environment records: Ambient environment is also very important for power system. So make following records of ambient environment after above operations:

- ① Ventilation
- ② Ambient temperature
- ③ Does installation distance meet the requirements?
- ④ Whether the ambient environment is faulty (such as dust or moisture)
- ⑤ How about the input and output battery wiring? Does the wire diameter meet the requirements? Is the power insulation leather damaged? Is the terminal loose?
- ⑥ Names, types, rated powers and other conditions of connected loads (customer can be consulted for this question)

2. Fault Type Recognition: After all indications have been recorded, refer to the fault message table and check the display fault codes. In most cases, the fault is caused by the external factors. Therefore, follow the principle of "External causes to internal causes" and depend on fault message table to locate and exclude the external faults.

Common external fault causes:

- ① Excessive loads
- ② Input and output overvoltage and undervoltage
- ③ Mains air switch is disconnected or mains input is abnormal
- ④ Output short circuit
- ⑤ Battery voltage is below the low voltage limit

3. If a fault is reported possibly due to internal cause, make a solution after fault location. Each key step shall be documented when the solution is implemented, so that it can be used for reference to remake a solution when the problem is not resolved.

4. If the above methods are still unable to handle the faults, please feedback the recorded information to the technical support engineers to coordinate the solution.

4.3 Fault Message Collection

4.3.1 LCD Panel Alarm Message Collection

When arriving at the in-situ, the service engineer needs to collect alarm messages as soon as possible so as to get an effective basis for fault analysis. Display details of the LCD panel (mainly fault codes), and the operating conditions of icons on the LCD panel shall be recorded. According to the fault codes and operating conditions of icons, we can preliminarily determine the fault types, thus achieve fault location.

Please refer to the “Alarm Codes and Fault Codes Query Table”, to carry out quick query of alarm code and fault codes and obtain corresponding handling suggestion.

4.3.2 Network Management Alarm Message Collection

If customer’s UPS system is connected with network management software, the maintenance personnel can download and export the current alarm messages and all the data through the network management software for analysis. For details, refer to the user manual of the corresponding network management software.

4.4 Common Faults and Handling Methods

Table 4-2 Common Faults and Handling Methods

When the UPS runs in fault mode, indications on the LCD are shown as below:

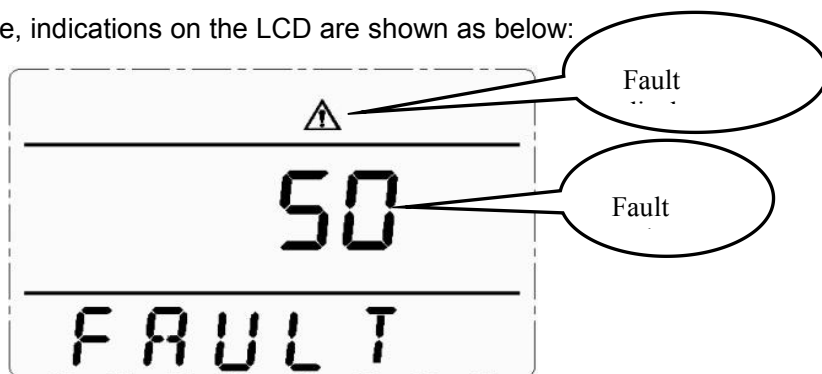

Faults	Causes	Solutions
LCD will display fault icon, the character of FAULT and fault code on the display area; buzzer beeps for a long time and fault code is 00—14	BUS voltage fault	Measure if the bus voltage is normal or contact your supplier.
LCD will display fault icon, the character of FAULT and fault code on the display area; buzzer beeps for a long time and fault code is 15-24	Soft start fault	Find the power on soft start part and check if the soft start resistance is damaged or please contact your supplier.
LCD will display fault icon, the character of FAULT and fault code on the display area; buzzer beeps for a long time and fault code is 25-39	Inverter voltage fault	Please contact your supplier.
LCD will display fault icon, the character of FAULT and fault code on the display area; buzzer beeps for a long time and fault code is 40—44	Over temperature inside the UPS	Confirm that the UPS is not overloaded and air outlet is not blocked. Wait for 10 minutes to cool the UPS and restart it. If the problem stills exists, please contact your supplier.

LCD will display fault icon, the character of FAULT and fault code on the display area; buzzer beeps for a long time and fault code is 45—49	Output short circuit	Turn off the UPS and remove all loads. Confirm the loads have no faults or inside short circuit. Restart the UPS. If the problem stills exists, please contact your supplier.
LCD will display fault icon, the character of FAULT and fault code on the display area; buzzer beeps for a long time and fault code is 50—54	Overload	Inspect the load capacity and remove unnecessary loads. Recalculate the power of loads and reduce the number of loads connected to the UPS and then inspect if the loads have faults.
LCD will display fault icon, the character of FAULT and fault code on the display area; buzzer beeps for a long time and fault code is 55—59	Input NTC fault	Please contact your supplier.
LCD will display fault icon, the character of FAULT and fault code on the display area; buzzer beeps for a long time and fault code is 60—64	Power supply fault	Find the power supply part and check if the power input and output are normal. If they are abnormal, please contact your supplier.
LCD will display fault icon, the character of FAULT and fault code on the display area; buzzer beeps for a long time and fault code is 65—69	Input fuse fault	Measure if the input fuse is damaged, and turn on the UPS again after replacement of damaged input fuse. If the UPS fails to be turned on, please contact your supplier.
LCD will display fault icon, the character of FAULT and fault code on the display area; buzzer beeps every 2 seconds and the fan icon on the LCD blinks	Fan fault	Inspect if the fan is properly connected, if the fan is locked or if the fan is damaged. If above conditions are all normal, please contact your supplier.
After the power-on button is pressed, the UPS fails to start up	Too short press on the power-on button	Press the power-on button for more than 2 seconds and start up the UPS.
	UPS input end is not properly connected or is the standard battery not connected	Properly connect the UPS to the utility power supply. For a standard UPS and the battery voltage is low, please firstly power off and then power on without loads.
	Internal fault	Please contact your supplier.
Short battery discharge time	Insufficient charge	Keep the UPS connected to the mains for more than 3 hours to recharge the battery.
	UPS overload	Inspect load capacity and remove unnecessary equipment.
	Battery aging, capacity declining	Replace the battery, and contact your supplier to obtain the battery and its components.
Mains is normal but there is no input to the UPS	UPS input circuit breaker is disconnected	Manually reset the circuit breaker.

4.5 Fault Codes Explanation and Handling Suggestions

Table 4-3 Fault Codes Explanation and Handling Suggestions

Fault Codes					Bypass output	Explanation	Handling suggestions
Bypass mode	Main mode	Battery mode	Self test mode	ECO mode			
0	1	2	3	4	Have	BUS high voltage	Please replace the main control board to retest. If the problem still exists, please check the PFC power section
5	6	7	8	9	Have	BUS low voltage	
10	11	12	13	14	Have	±BUS voltage imbalance	
15	16	17	18	19	Have	BUS soft-start fails	
20	21	22	23	24	Have	INV soft-start fails	Please replace the main control board to retest. If the problem still exists, please check the INV power section
25	26	27	28	29	Have	INV high voltage	
30	31	32	33	34	Have	INV low voltage	
35	36	37	38	39	Have	BUS discharge time is too long	Power off the UPS and then power on. If the problem still exists, please check the main control board, INV power section and PFC power section, and retest.
40	41	42	43	44	Have	Over-temperature fault	Please check if the fan on the rear panel is normal, if the fan outlet is blocked , or if the distance from the rear panel to the wall is less than 50cm (For power mode over-temperature fault in mains mode, when the internal temperature decreases to a certain value, the UPS will automatically power on)
45	46	47	48	49	None	INV short circuit	If inverter output is short circuited, please repair the INV power component; If short circuit occurs inside the loads, please check if the loaded equipment is normal; after confirmation that loads are normal, restart the UPS and connect loads.
50	51	52	53	54	None	Overload fault	Disconnect the loads and turn off the UPS, remove some unnecessary loads, turn on the UPS again and connect the loads again.
55	56	57	58	59	Have	Loads abnormal	UPS is switched from bypass mode back to inverter mode. Please check if the IGBT tube on the INV power component is normal and if the relay is stuck. If the loads are abnormal, please check load status.
60	61	62	63	64	Have	Power off fault	Please check whether the first button on the LCD panel is pressed down and cannot rebound. If it is normal, please replace the wires between the LCD panel and the main control board as well as the main control board and power board, and perform re-test.
65	66	67	68	69	Have	Mains fuse is disconnected	This group of fault codes are not enabled

70	71	72	73	74	Have	Communication fault	This group of fault codes are not enabled
75	76	77	78	79	Have	Communication fault	This group of fault codes are not enabled
80	81	82	83	84	Have	Relay is stuck	Please check if the contact of relay on the power board is stuck. If any, please replace.
85	86	87	88	89	Have	Mains SCR tube fault	This group of fault codes are not enabled

5 PCB Replacement

Inside the UPS just has a power board and a main control board, the EMI board, SPS board, CHGR board and drive board are integrated on the power board.

1KS



2KS

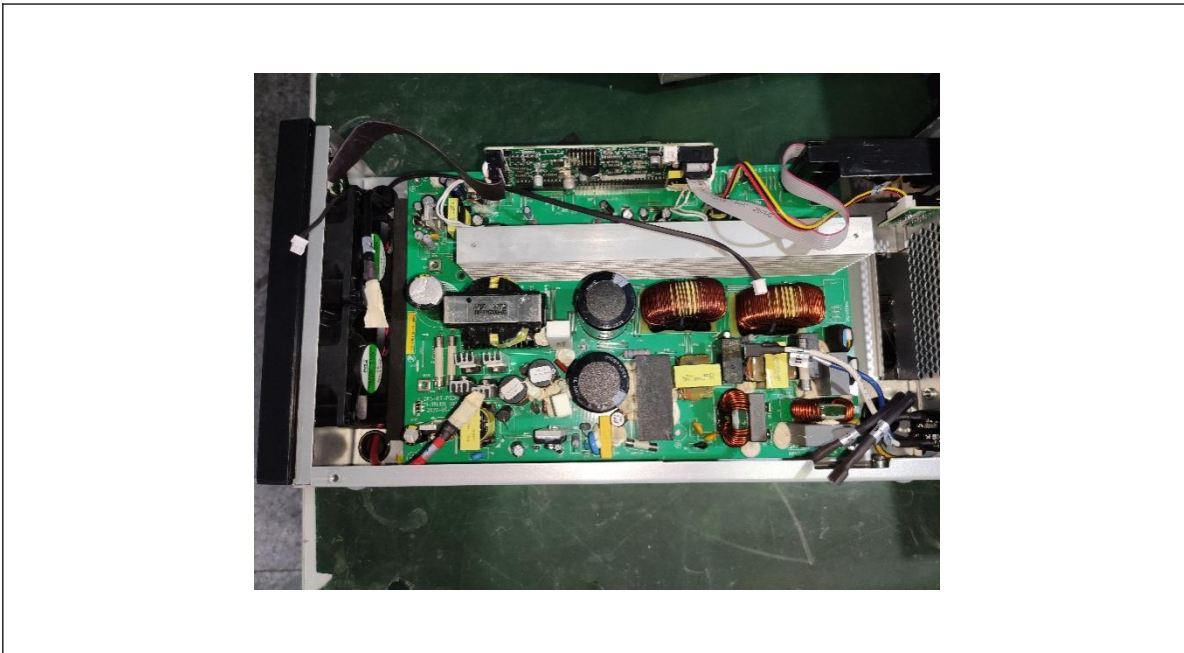

6 PCB Maintenance & Module Maintenance

Maintenance of high-frequency 1-3K UPS requires the maintenance personnel to have basic knowledge of circuit theory and power electronics, to understand the relevant circuit topology. In addition, the improvement of maintenance skills relies on long-term maintenance experience, so during the maintenance process, please make maintenance records that can help maintenance personnel to quickly locate and handle the faults, and improve maintenance efficiency.

According to the actual usage, vulnerable components of the high-frequency 1-3K UPS are PFC, INV, DC/DC and CHGR; following sections briefly introduce the maintenance of such components.

6.1 REC&PFC Power Components Maintenance

Vulnerable components on the PFC are shown as follows (Sort according to vulnerability):

1. IGBT tube Q9(1K), Q14(2K/3K)and corresponding driving resistance.
2. Power diodes D19/D20 (1-3K).
3. PFC_IGBT tube's drive modules optical coupler U9.
4. Mains rectifier REC1.
5. Resistance and capacitor of RC absorption circuit of PFC_IGBT.
6. Other peripheral components.

Detailed maintenance steps:

Step 1: Check if there are copper foil corrosion and rust phenomena on the whole power board. A multimeter can be used as an auxiliary tool. If there are corroded copper foils, please resolder.

Step 2: Visually check if there are obviously burnt or cracked components on the entire power board. If any, please replace.

Step 3: Use a multimeter in the Ohm range to check if the battery fuse F3/F4(1K), F9/F10(2-3K) is damaged. If damaged, please replace.

Step 4: Use a multimeter in the diode range to measure the GE ends and EC ends of IGBT Q9(1K) and Q14(2-3K). If it is measured that the diode voltage drop is too low (less than 0.1V), or there is direct short circuit or open circuit, you need to replace the corresponding IGBT.

Notes: When replacing IGBT, if corresponding insulation pads are burned to be black, burned to be damaged, burned through, burned to be melted, the ceramic piece is damaged, etc., they are also needed to be replaced. After replacement, tighten the screws to ensure good heat dissipation of IGBT.

Step 5: Use a multimeter in the Ohm range to measure the driving resistance of IGBT Q9(1K) and Q14(2-3K). For 1K, the resistance of R80/R88 is 27Ω/22Ω, and the resistance of D15 that is connected in parallel at the two ends of R80 is 27Ω around. If the resistance is too large or too small, corresponding driving resistance and diodes shall be replaced. For 2-3K, the resistance of R75/R71 is 27Ω/22Ω, and the resistance of D24 that is connected in parallel at the two ends of R75 is 22Ω around. If the resistance is too large or too small, corresponding driving resistance and diodes shall be replaced.

Note: If there is any change in the resistance values of R80 / R88(1K) and R75 / R71(2-3K), please perform specific check according to the resistance.

Step 6: Use a multimeter in the diode range to test the power diodes D19/D20 (1-3K). If it is measured that the forward voltage drop is too low (less than 0.1V), or there is reverse voltage drop, the diode may have been damaged, and needs to be replaced.

Step 7: Use a multimeter in the diode range to test PFC rectifier bridge REC1. If it is measured that the forward voltage drop is too low (less than 0.1V), or there is reverse voltage drop, the diode may have been damaged, and needs to be replaced.

Note: In general, rectifier bridge damage is accompanied by fuse damage. So please detect about this.

Step 8: After completing the maintenance items from step 4 to step 7, repeat these steps. If the measured values are normal, proceed to the next step. If they are abnormal, use a multimeter in the Ohm range to check the PFC drive module optical coupler. Check the resistance value of each pin of the drive optical coupler and compare it with the value of the normal power board. If the value differs greatly, you need to replace the corresponding drive optical coupler.

Step 9: Use a multimeter in the Ohm range to detect if the mains sampling resistance is normal and if the \pm BUS sampling resistance is normal. If the resistance is too large or too small, it is necessary to check for dry joint, loose weld, continuous tin electrodeposit, crack and other faults. If above abnormal phenomenon occurs, corresponding SMD resistor needs to be replaced.

Note: If necessary, SMD resistor can be removed for independent measuring.

After the above steps are completed, it indicates that preliminary maintenance of the PFC power board is finished. Before turning the power on, it is necessary to carefully check the wiring, and use the drive test program control board to test whether all the drives are normal; after drive test, use DC stabilized power supply and AC power supply with current limiting function to carry out current-limiting power-on test. If the test is passed, the UPS can be normally powered on and the test with loads is performed. If there is a problem occurred during the test, you need to perform maintenance again follow the above steps. (See Chapter 7: Commissioning after maintenance)

6.2 INV Power Components Maintenance

Vulnerable components on the INV are shown as follows (Sort according to vulnerability):

1. IGBT Q10/Q11(1K), Q6/Q10(2-3K)and corresponding driving resistance.
2. Drive optical coupler U10/U9 of IGBT Q10/Q11(1K)and drive optical coupler U1/U2 of IGBT Q6/Q10 (2-3K).
3. Resistance and capacitor of RC absorption circuit of INV_IGBT.
4. Other peripheral components.

Detailed maintenance steps:

Step 1: Check if there are copper foil corrosion and rust phenomena on the whole power board. A multimeter can be used as an auxiliary tool. If there are corroded copper foils, please resolder.

Step 2: Visually check if there are obviously burnt or cracked components on the entire power board. If any, please replace.

Step 3: Use a multimeter in the diode range to measure the GE ends and EC ends of IGBT Q10/Q11(1K)and Q6/Q10(2-3K). If it is measured that the diode voltage drop is too low (less than 0.1V), or there is direct short circuit or open circuit, you need to replace the corresponding IGBT.

Notes: When replacing IGBT, if corresponding insulation pads are burned to be black, burned to be damaged, burned through, burned to be melted, the ceramic piece is damaged, etc., they are also needed to be replaced. After replacement, tighten the screws to ensure good heat dissipation of IGBT.

Step 4: Use a multimeter in the Ohm range to measure the driving resistance of IGBT Q10/Q11(1K)and Q6/Q10(2-3K). For 1K, the resistance of R72R64/R81R75 is 27 Ω /22 Ω , and the resistance of D25/D26 that is connected in parallel at the two ends of R72/R64 is 27 Ω around. If the resistance is too large or

too small, corresponding driving resistance and diodes shall be replaced. For 2-3K, the resistance of R153R156/R152R155 is 33Ω/27Ω, and the resistance of D35/D34 that is connected in parallel at the two ends of R153/R156 is 33Ω around. If the resistance is too large or too small, corresponding driving resistance and diodes shall be replaced.

Note: If there is any change in the resistance values of R72R64/R81R75(1K) and R153R156/R152R155(2-3K), please perform specific check according to the resistance.

Step 5: After completing the maintenance items in step 4, repeat measurement from step 3 to step 4. If the measured values are normal, proceed to the next step. If they are abnormal, use a multimeter in the Ohm range to check the INV drive optical coupler. The red probe is grounded to measure the resistance values of pins of the drive optical coupler, and the measure values are compared with the values on the normal power board. If the value has a large difference, you need to replace the corresponding drive optical coupler; where the corresponding drive optical coupler of Q10/Q10(1K) is U10/U9 and the corresponding drive optical coupler of Q1Q2/Q3Q4(2-3K) is U1/U2.

After the above steps are completed, it indicates that preliminary maintenance of the INV board is finished and power-on test is needed. Before turning the power on, it is necessary to carefully check the wiring, and use the drive test program control board to test whether all the drives are normal; after drive test, use DC stabilized power supply with current limiting function to carry out current-limiting power-on test. If the test is passed, the UPS can be normally powered on and the test with loads is performed. If there is a problem occurred during the test, you need to perform maintenance again follow the above steps. (See Chapter 7: Commissioning after maintenance)

6.3 DC/DC Power Components Maintenance

Vulnerable components on the DC/DC are shown as follows (Sort according to vulnerability):

1. MOS tubes Q12/Q13/Q15/Q14(1K), Q13/Q12/Q8/Q9(2-3K) and corresponding driving resistance.
2. Drive circuit U18Q21, Q22Q19 of MOS tubes Q12/Q13/Q15/Q14(1K) and drive circuit U11Q19, U12Q21 of MOS tubes Q13/Q12/Q8/Q9(2-3K).
3. Resistance and capacitor of RC absorption circuit of MOS tubes.
4. DC/DC secondary-side push-pull diodes D21/D7/D18/D22 (1K) and D9/D18/D13/D21 (2-3K)。
5. DC/DC fuse and DC/DC electrolytic capacitor.
6. Other peripheral components.

Detailed maintenance steps:

Step 1: Check if there are copper foil corrosion and rust phenomena on the whole power board. A multimeter can be used as an auxiliary tool. If there are corroded copper foils, please resolder.

Step 2: Visually check if there are obviously burnt or cracked components on the entire power board. If any, please replace.

Step 3: Use a multimeter in the diode range to measure the GS ends and DS ends of MOS tubes Q12/Q13/Q15/Q14(1K) and Q13/Q12/Q8/Q9(2-3K). If it is measured that the diode voltage drop is too low (less than 0.1V), or there is direct short circuit or open circuit, you need to replace the corresponding MOS tube.

Notes: When replacing MOS, if corresponding insulation pads are burned to be black, burned to be damaged, burned through, burned to be melted, the ceramic piece is damaged, etc., they are also needed to be replaced. After replacement, tighten the screws to ensure good heat dissipation of MOS.

Step 4: Use a multimeter in the Ohm range to measure the driving resistance of MOS tubes Q12/Q13/Q15/Q14(1K) and Q13/Q12/Q8/Q9(2-3K). For 1K, the resistance of R77/R76/R79/R78 is 27Ω. If the resistance is too large or too small, corresponding driving resistance shall be replaced. For 2-3K, the resistance of R162/R157/R173/R171 is 33Ω. If the resistance is too large or too small, corresponding driving resistance shall be replaced.

Note: If there is any change in the resistance values of R77/R76/R79/R78(1K) and R162/R157/R173/R171(2-3K), please perform specific check according to the resistance.

Step 5: After completing the maintenance items in step 4, repeat measurement from step 3 to step 4. If the measured values are normal, proceed to the next step. If they are abnormal, use a multimeter in the Ohm range to check the MOS drive circuit. Check the resistance value of each pin of the drive circuit and compare it with the value of the normal power board. If the value is significantly different, you need to replace the corresponding drive module.

Step 6: Use a multimeter in the diode range to test the DC/DC secondary-side push-pull power diodes D21/D7/D18/D22(1K) and D9/D18/D13/D21(2-3K). If it is measured that the forward voltage drop is too low (less than 0.1V), or there is reverse voltage drop, the diode may have been damaged, and needs to be replaced.

Step 7: Use a multimeter in the ohm range to detect if the DC/DC fuse F3/F4(1K), F9/F10(2-3K) is damaged. If damaged, please replace; in addition, due to large battery ripple or improper battery voltage, the DC/DC electrolytic capacitor in the long-term use is prone to bulging, leakage or failure. If a similar situation occurs, replacement is necessary.

After the above steps are completed, it indicates that preliminary maintenance of the DC/DC power components is finished and power-on test is needed. Before turning the power on, it is necessary to carefully check the wiring, and use the drive test program control board to test whether all the drives are normal; after drive test, use DC stabilized power supply with current limiting function to carry out current-limiting power-on test. If the test is passed, the UPS can be normally powered on and the test with loads is performed. If there is a problem occurred during the test, you need to perform maintenance again follow the above steps. (See Chapter 7: Commissioning after maintenance)

6.4 CHGR Charger Board Maintenance

Detailed maintenance steps:

Step 1: Check if there are copper foil corrosion and rust phenomena on the whole charger board. A multimeter can be used as an auxiliary tool. If there are corroded copper foils, please resolder.

Step 2: Visually check if there are obviously burnt or cracked components on the entire charger board. If any, please replace.

Step 3: Use a multimeter to measure key components and detect whether the components are damaged or not. Damaged components shall be replaced with ones of the same specifications.

Step 4: Build a test platform for the maintained CHGR board. Connect wires and perform current-limiting mains connection. Use a multimeter to measure if the charging voltage between BAT + and BAT - is normal. If it is abnormal, maintain the board again; if it is normal, it indicates the CHGR board is preliminarily fixed and you can proceed to the next step.

Step 5: After power-on through the battery, connect the UPS to the mains and use DC ammeter to

measure if the maximum charging current is normal. If it is abnormal, maintenance again is needed; if it is normal, it indicates the CHGR board is completely fixed.

Charge Current Standard:

Standard UPS 1KS/2KS/3KS: $1A \pm 0.3A$;

Charge Voltage Standard: floating charge voltage: $13.5V \times \text{number of cells}$

Number of cells	Floating charge voltage V
2	$27.1 \pm 0.6V$
3	$40.5 \pm 0.9V$
4	$54.2 \pm 1.2V$
6	$81.0 \pm 1.8V$
8	$108.4 \pm 2.4V$

Charger Board Wiring Diagram

Charger working principle

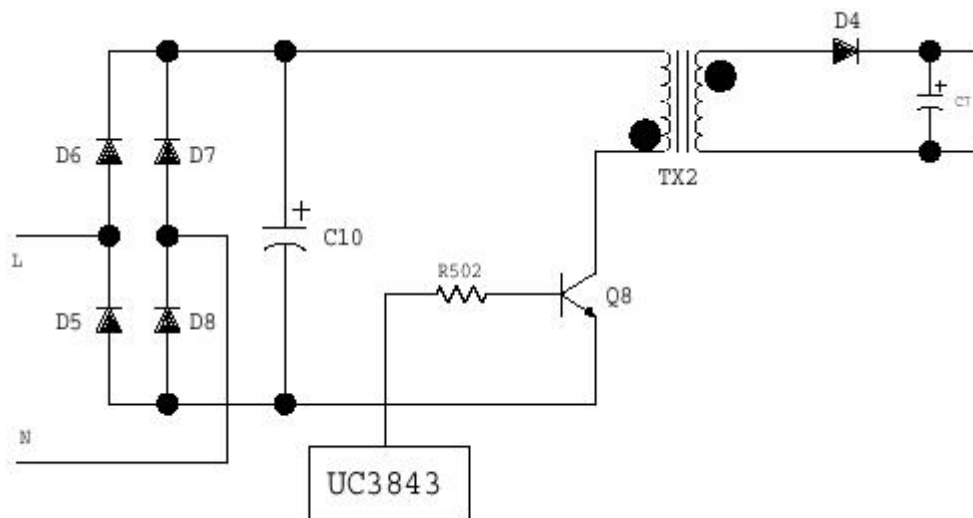

Figure 6-1 Basic Circuit of High Frequency 1-3K UPS Charger

Standard UPS charger module

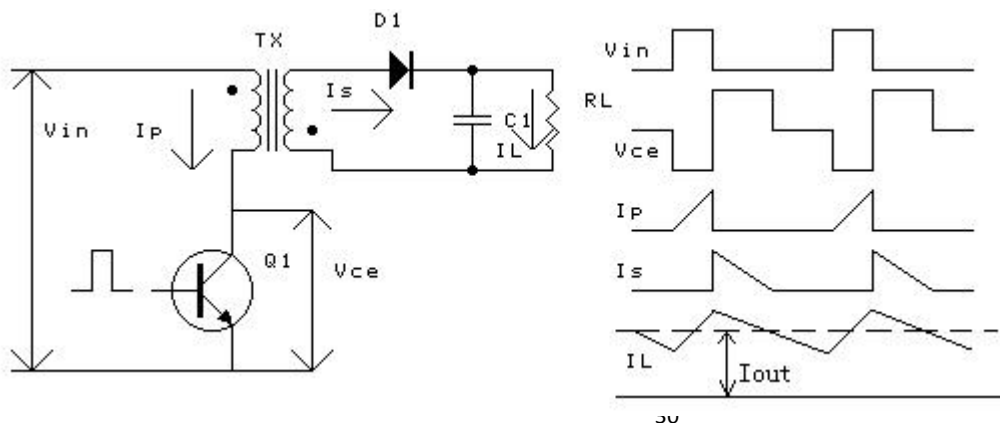

Figure 6-2 Isolation Flyback Converter Basic Circuit and Waveform

1. Working Principle:

When the Q1 is connected, there will be current gradually flowing through the primary winding of transformer, and storing energy therein. The primary winding and secondary of transformer come with opposite polarities, so the diode has reverse bias, without energy transferred to the loads. When the Q1 is disconnected, the secondary winding polarity is reversed, current flows through the diode, output capacitor is charged and there is current flowing in loads.

2. Charger operating:

When there is mains input, the rectifier circuit composed of D5 ~ D8 and C10 turns the AC input into DC, and supplies power to the UC3845 through the voltage division circuit. After the charger starts working, the auxiliary winding of the isolation flyback converter provides working power supply for the UC3845.

The charger works under the control of UC3845. Take the voltage feedback signal TL431 R through voltage division circuit and compare it with the 2.5V reference voltage to control voltage drop between the TL431 AK, allowing it to work with the optical coupler connected in series at a different current. According to $IC = BID$, the voltage of 3845PIN1 is controlled to control DUTY, so as to achieve stable output; thanks to UC3845 simultaneous sampling of transformer primary current signal, the charger realizes current limiting, ensuring that when charge voltage is low caused by low battery voltage, charge current is unlikely to be too large to protect the battery from being damaged.

2) Charger Module Features

A. CHGR ON/OFF Control

In mains mode (normal), CHGR ON allows the charger to charge the battery; in battery mode, CHGR OFF means the charger stop charging the battery.

Control method: When the CHGOFF-signal is at high level, U2 is not powered on and the charger works normally; in battery mode, the CHGOFF-signal is at low level, U2 is energized and voltage is input from PIN7 to PIN3, lifting the level of PIN3 to more than 1V. Turn off PWM output and the charger stop charging the battery.

In addition to high and low level states, the CHGR OFF-signal can work under PWM(2KHZ) mode. Based on control of PWM DUTY, the DC voltage overlaid on the 3845 PIN3 can be different, to adjust the charge current. According to input voltage, internal temperature and battery, the charge current can be adjusted.

B. CHGR Level Control Logic

- 1) When the power is turned on, floating charge is firstly performed.
- 2) When the battery is disconnected, floating charge is remained.
- 3) After the charger enters floating charge, the battery voltage shall be determined at first. If the voltage is larger than 13V per cell, maintain floating charge, otherwise enter equalizing charge.
- 4) After the charger enters equalizing charge, the battery voltage shall also be determined; if the voltage is larger than 14.1V per cell (last 20ms), switch to floating charge; if the voltage is larger than 15V per cell (last 2ms) switch to floating charge as well.
- 5) Start counting after the charger enters equalizing charge. When the charge time $T=12h$, forcefully switch it to floating charge (12h is default; time is settable).

- 6) In floating charge stage, if the time last 20s as voltage is larger than 13.9V, the charger is considered to be faulty (alarm code is 0080).
- 7) During charging (floating charge or equalizing charge), if battery voltage is larger than 14.5 per cell (last 10s), the charger overcharge fault is reported and it is switched to floating charge.
- 8) If the charger overcharge occurs 5 times in one hour, the charger overcharge fault is reported (alarm code is 0080), the buzzer beeps every second, battery icon blinks and the charger is fixed in floating charge; if battery overcharge is detected in battery mode, it cannot be switched to mains mode until the battery voltage is less than 13.5V per cell.

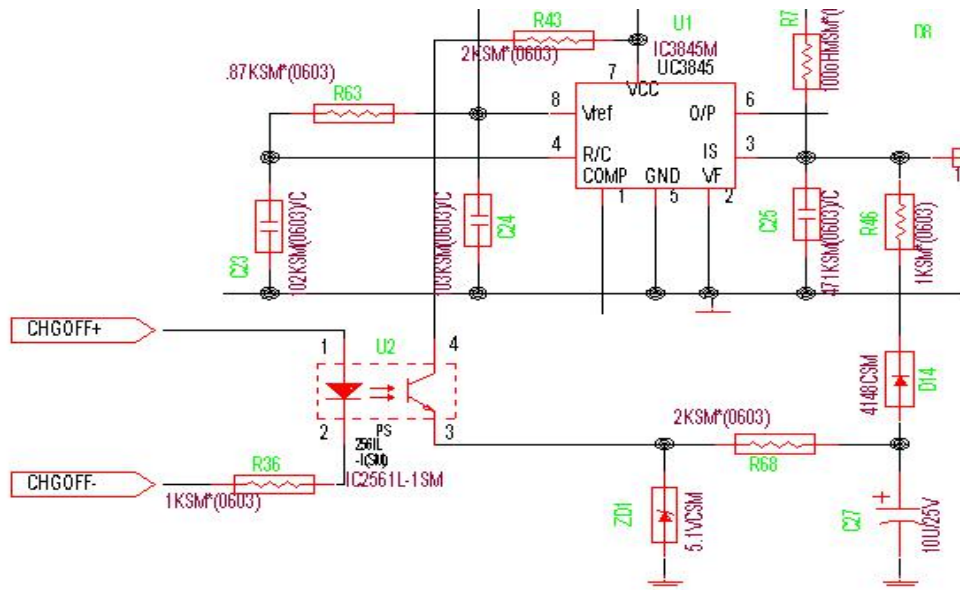

Figure 6-3 Charger Turn-Off Schematic Diagram

7 Commissioning after Maintenance

7.1 PCB Installation

After maintenance, the PCBs (mainly including power board, charger board and main control board) shall be installed on the UPS for commissioning so as to confirm if they are fixed.

In reference to Chapter 5, install maintained PCBs on the UPS and ensure correct position and wiring.

7.2 Inspection after Installation

- Check and confirm that internal PCBs well installed.
- Check and confirm that internal wiring is correct.
- Check if the cable is tightened at the connection.
- Check if all wirings are neat, loose, and if the binding of cable complies with the process specifications.
- Check if grounding is reliable.
- Operators have to wear a pair of insulated shoes.

7.3 Drive Test

Note: Mains cannot be connected when using drive test program control board, and the battery fuse shall be removed, otherwise the UPS may be damaged.

After PCB maintenance is completed, fuse of battery is removed and the PCB is installed on to the UPS, confirm the UPS is not connected to the mains and main control board is changed with drive test program control board.

Operating Instructions:

1. Confirm the UPS is not connected to mains or external battery;
2. Use a probe to pinch the drive of components on the power board (IGBT, GE pole, MOS, GE pole);
3. Switch on the battery or DC power source, press the power-on button and the power board starts to work, supplying the drive test program control board with stable power, and the control board sends PFC, INV and DC/DC drive in accordance with the set procedure;
4. Use oscilloscope to capture the drive waveform, and compare them with the following waveform. In case of abnormal drive waveform, the PCB is required to be maintained again. (In addition to damage of drive module, drive resistance and IGBT, other factors such as copper foil crack, abnormal wiring, etc. are also possible to cause abnormal drive waveform).

PFC Power IGBT Drive Waveform, as shown below:

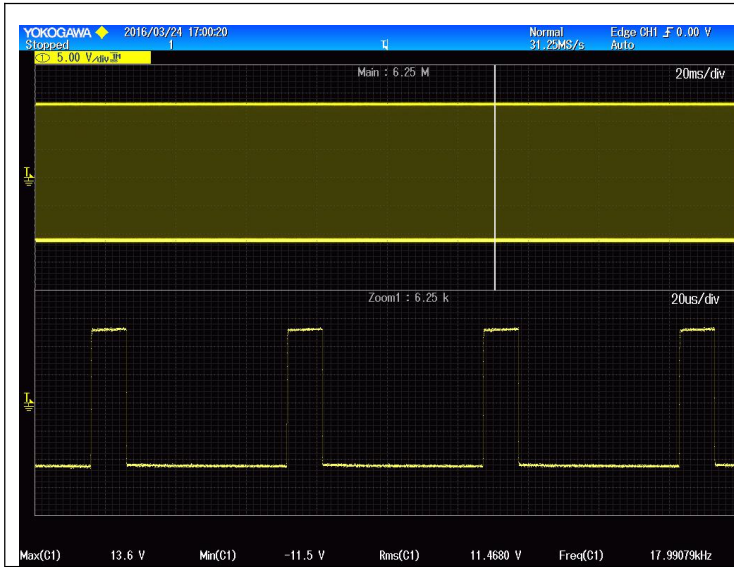

Channel One: GE end waveform

Duty cycle of PFC IGBT drive goes up with the increase of loads. The maximum duty cycle is about 95%, with the amplitude of +16 V, -8V or around, and the frequency of 18KHZ.

Note: It is currently the duty cycle of board without load

INV Power IGBT Drive Waveform, as shown below:

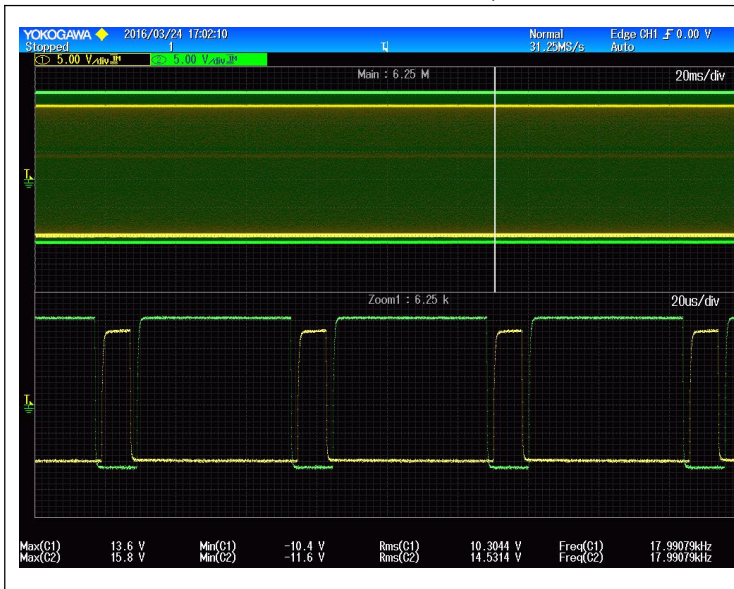

Channel One: Positive edge GE end waveform

Channel Two: Negative edge GE end waveform

As shown in the figure, for INV power IGBT, the positive edge and negative edge IGBT drive come with inverse waveform. The duty cycle changes with the output waveform phase. Amplitude is +16 V, -8V or around, and the frequency is 18KHZ.

DC/DC Power MOS Tube Drive Waveform, as shown below:



Channel One: Positive edge GE end waveform

Channel Two: Negative edge GE end waveform

As shown in the figure, the positive edge and negative edge MOS drive of DC/DC power come with inverse waveform. The duty cycle goes up with the increase of loads. The maximum duty cycle is 45%, with the amplitude of 12V around, and the frequency of 50KHZ.

Note: It is currently the duty cycle of board without load

7.3 Power-On Commissioning

Step 1: The output voltage of the DC source is adjusted to be the rated DC input voltage of UPS and the output current is limited to 5A.

Step 2: Use oscilloscope, multimeter, voltmeter or other devices to monitor the BUS voltage and INV voltage.

Step 3: Turn on the output switch of DC source and press the first button on panel. Then the screen lights up. Observe if the power, battery voltage, input voltage, output voltage, frequency and other information are normal. If normal, press the key combination to turn on the UPS. Observe the BUS voltage rise condition. After the positive and negative BUS voltage rise to about 345V, the INV voltage begins to rise; when the INV voltage rises to 220V (set the output voltage), observe the screen display information, and pay special attention to the output voltage or frequency. If the output voltage or frequency is abnormal, it indicates that the relay is stuck or BYPASS is damaged.

Step 4: Turn off the UPS and after the BUS voltage is completely discharged, connect the AC source to the UPS input end, and set the AC output voltage to 220V and output current to 5A around.

Step 5: Turn on the output switch of AC source and then the UPS screen lights up. Observe if the BUS voltage goes up smoothly. When the BUS voltage rises to input voltage peak value (310V around), press the key combination to power on. When BUS voltage rises to 360V, INV voltage soft-start begins. After INV voltage and frequency are completely up to bypass voltage, UPS will automatically switch to LINE mode. Observe whether the information displayed on the screen is right or not.

Step 6: Connect the UPS to DC source and press the key combination on panel to start self-test. Observe if the UPS can normally detect the battery. After self-test, mains mode and battery mode switching test is performed.

Note: If the UPS can work properly in battery mode and mains mode, it is preliminarily recognized that if UPS has been fixed and you can proceed to the next step. If the UPS does not work properly after above operations, then it is necessary to do further troubleshooting.

Step 7: Turn off the UPS and change the AC source and DC source to respectively mains and battery. Repeat the operations from step 3 to step 5.

Step 8: Perform load test and overload test respectively in the mains mode and battery mode. If the UPS can work properly, it is indicated to have been fixed, and the aging operation shall be executed. If the UPS does not work properly, then you need to do further troubleshooting.

TIPS: If having suitable conditions, try to use oscilloscope and high voltage probe to measure the waveform of + BUS, -BUS, INV voltage, output current, etc. during above operations. This is more helpful in judging whether the UPS has been repaired.

8 Appendix: Wiring Diagram

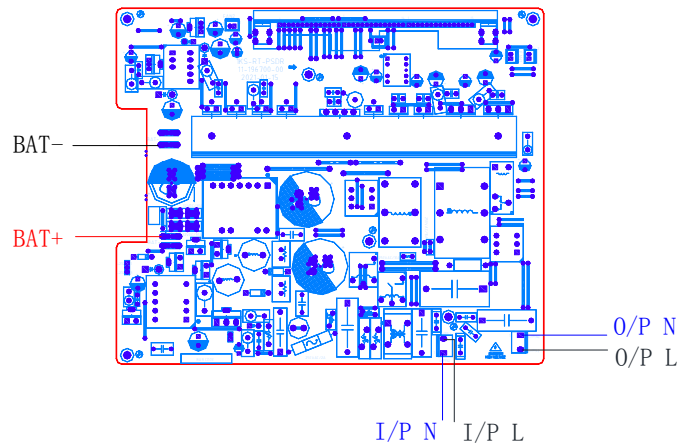

Figure 1: 1KS Main Circuit Wiring Diagram

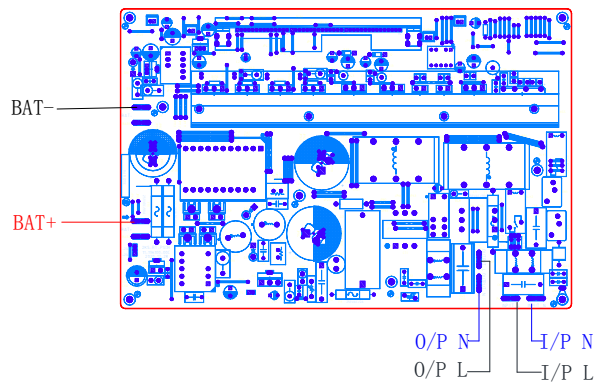

Figure 2: 2KS Main Circuit Wiring Diagram

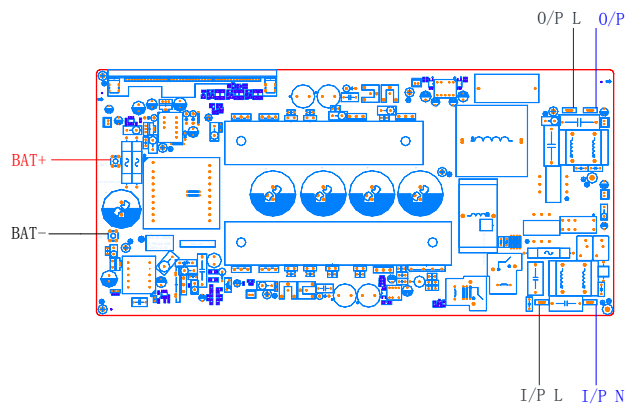

Figure 3: 3KSRT Main Circuit Wiring Diagram

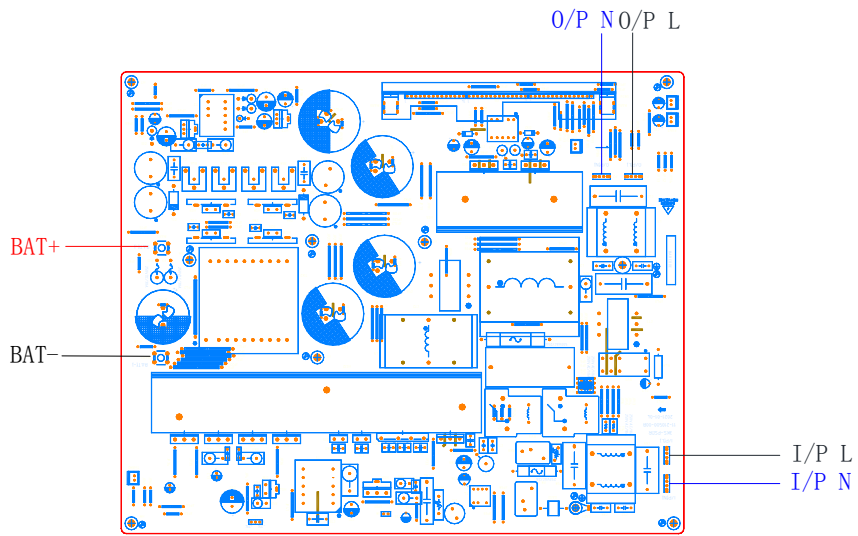

Figure 4: 3KS Tower Type Main Circuit Wiring Diagram