



**International Series
GTFX and GVFX
Grid-Interactive
Inverter/Charger
Installation Manual**

About OutBack Power Systems

OutBack Power Systems is a leader in advanced energy conversion technology. Our products include true sine wave inverter/chargers, maximum power point charge controllers, system communication components, as well as breaker panels, breakers, accessories, and assembled systems.

Contact Information

Telephone: (+1) 360.435.6030 (North America)
(+34) 93.654.9568 (Barcelona, Spain)

Fax: (+1) 360.435.6019

Address: North America
19009 62nd Avenue NE
Arlington, WA USA

E-mail: Support@OutbackPower.com

Web: www.OutBackPower.com

Disclaimer

UNLESS SPECIFICALLY AGREED TO IN WRITING, OUTBACK POWER SYSTEMS:

(a) MAKES NO WARRANTY AS TO THE ACCURACY, SUFFICIENCY OR SUITABILITY OF ANY TECHNICAL OR OTHER INFORMATION PROVIDED IN ITS MANUALS OR OTHER DOCUMENTATION.

(b) ASSUMES NO RESPONSIBILITY OR LIABILITY FOR LOSS OR DAMAGE, WHETHER DIRECT, INDIRECT, CONSEQUENTIAL OR INCIDENTAL, WHICH MIGHT ARISE OUT OF THE USE OF SUCH INFORMATION. THE USE OF ANY SUCH INFORMATION WILL BE ENTIRELY AT THE USER'S RISK.

Warranty Summary

OutBack Power Systems Inc. warrants that the products it manufactures will be free from defects in materials and workmanship for a period of five (5) years subject to the conditions set forth in the warranty detail found inside the back cover of this manual.

OutBack Power Systems cannot be responsible for system failure, damages, or injury resulting from improper installation of their products.

Notice of Copyright

International Series GTFX and GVFX Grid-Interactive Inverter/Charger Installation Manual

©March 2010 by OutBack Power Systems. All Rights Reserved.

Trademarks

OutBack Power is a registered trademark of OutBack Power Systems.

Date and Revision

March 2010, Revision A

TABLE OF CONTENTS

The International Series GTFX and GVFX Grid-Interactive Inverter/Charger.....	2
International Series GTFX and GVFX Inverter/Charger Models	2
Parts Included.....	2
Safety Instructions.....	3
System Protection.....	5
DC Wiring Origination.....	5
AC Wiring Origination.....	6
AC Wiring Compartment Board.....	6
Low Voltage Terminals.....	7
AC and DC Grounding Requirements.....	8
FX Parts and Accessories.....	9
Mounting.....	10
Wire Connections.....	11
AC	11
DC	12
Torque Requirements.....	12
Battery Wiring Examples	13
AC Wiring Notes	21
Low Voltage Wiring.....	22
Inverter and On/Off.....	22
Auxiliary Output (AUX+ / AUX-).....	23
XCT+ / XCT-.....	23
RTS, MATE/HUB Wiring.....	24
Stacked FX Systems.....	25
Installation Types:	
Single FX System.....	26
Parallel Dual FX System	27
Parallel Quad FX System	28
3-Phase System.....	30
Generator Auto Start.....	33
Multiple AC Sources.....	34
Installation Check List.....	35
Specifications.....	36
Voltage, Power, and Frequency Ranges	41
Current Ranges	42
Recommended DC Breaker and Cable Sizes	43
Maintenance.....	43
FX Default Values	45
Comparative Wire Sizes.....	48
Warranty.....	49
Product Registration.....	53

The International Series GTFX and GVFX Grid-Interactive Inverter/Charger

The International Series GTFX and GVFX Inverter/Chargers (also referred to as the FX series) offer a complete power conversion system — DC to AC, battery charging, and an AC transfer relay — which provide complete grid-interactive service. They can also be used in a stand-alone or back-up application. These systems are designed for indoor or enclosed locations.

OutBack Power Systems does everything possible to assure the components you purchase will function properly and safely when installed as instructed according to local and national electrical codes. Please read all of the following instructions and the instructions that come with any other OutBack components that make up your power system. Further instructions on individual FX set-ups as well as systems assemblies are included with the FLEXware manuals.

The International Series GTFX and GVFX inverters produce an output voltage of 230 Vac per inverter.

NOTE: This product is not CE compliant for grid-interactive operations.

The *International Series GTFX and GVFX Grid-Interactive Inverter/Charger Installation Manual* covers the following information:

- Safety
- FX parts, standard and optional
- Initial inspection of the component
- Preparing the mounting surface
- Fastening the FX to the mounting surface
- General electrical information



International Series Grid-Interactive Inverter/Charger Models

Sealed Units (designed for harsher environments, but still require enclosed protection)

- GTFX2012E (12 Vdc/2000 VA)
- GTFX2024E (24 Vdc/2000 VA)
- GTFX2348ET (48 Vdc/2300 VA)

Vented Units (designed for protected environments)

- GVFX2612E (12 Vdc/2600 VA)
- GVFX3024E (24 Vdc/3000 VA)
- GVFX3048E (48 Vdc/3000 VA)

Each model FX has a single phase output marked with this symbol: 
Each inverter puts out a sine wave waveform marked with this symbol: 

Parts Included

- One International Series GTFX or GVFX Inverter/Charger
- One “WARNING ELECTRICAL SHOCK” sticker to place on the exterior of the FX
- One packet of silicone grease to protect CAT 5 cable connections
- One installation manual
- One programming manual
- One Turbo Kit (sealed units)
- One DC Wiring Cover or DCC (vented units)



IMPORTANT SAFETY INSTRUCTIONS

READ FIRST!

SAVE THESE INSTRUCTIONS

Read all instructions and cautionary markings on the FX, the batteries and all appropriate sections of this installation and user manual as well as other component manuals before using the system.

Be cautious around electricity, electrical components, and batteries. Shocks, burns, injury, and even death can occur if an installer comes in contact with electricity.

Install all components and wiring according to national and local electrical and building codes. This includes:

- Submitting a plan to the local building department
- Passing inspection
- Requiring a licensed electrician to do the work when mandated

OutBack Power Systems cannot be responsible for system failure, damages, or injury resulting from improper installation of their products.

Use only the recommended DC and AC wire sizes or greater. Be sure all wires are in good condition.

Install the FX in a dry location, preferably indoors.



- Install the FX in a shaded area out of direct sunlight for best operation.
- For installations where the FX may be exposed to water spray, a sealed GTFX must be used and mounted either with the base down (shelf mounting) or with the AC wiring compartment facing down (wall mounting).
- If mounted with the base down, water cannot be allowed to accumulate around the FX's base. There is a drainage system on the base of the FX to dispel condensation. If submerged, water can enter this drain and cause failure.
- The Vented FX (GVFX) must be installed in a weather-proof enclosure or enclosed area. It is not designed for exposure to water or excessive wind-blown dust and debris.

INITIAL INSPECTION

Your FX is stoutly packaged for secure shipping. Please inspect the packaging and component for damage prior to installation.

WARNING: EXPLOSION HAZARD. WORKING NEAR LEAD ACID BATTERIES CAN BE DANGEROUS. BATTERIES GENERATE EXPLOSIVE GASES DURING NORMAL OPERATION.

Design the battery enclosure to prevent accumulation and concentration of hydrogen gas in “pockets” at the top of the enclosure. Vent the battery compartment from the highest point to the outside. A sloped lid can also be used to direct the flow of hydrogen to the vent opening.

CAUTION

To reduce risk of injury, charge only deep-cycle lead acid, lead antimony, lead calcium, gel cell or absorbed glass mat type rechargeable batteries. Other types of batteries may burst, causing personal injury and damage. Never charge a frozen battery.

PERSONAL PRECAUTIONS

- Someone should be within range of your voice to come to your aid if needed.
- Keep plenty of fresh water and soap nearby in case battery acid contacts skin, clothing, or eyes.
- Wear complete eye protection. Avoid touching eyes while working near batteries. Wash your hands with soap and warm water when done.
- If battery acid contacts skin or clothing, wash immediately with soap and water. If acid enters an eye, flood the eye with cool running water at once for at least 15 minutes and get medical attention immediately following.
- Baking soda neutralizes lead acid battery electrolyte. Keep a supply on hand in the area of the batteries.
- NEVER smoke or allow a spark or flame in vicinity of a battery or generator.
- Be extra cautious to reduce the risk of dropping a metal tool onto batteries. It could short-circuit the batteries or other electrical parts which can result in fire or explosion.
- Remove personal metal items such as rings, bracelets, necklaces, and watches when working with a battery or other electrical current. A battery can produce a short circuit current high enough to weld a ring or the like to metal, causing severe burns.

SYSTEM PROTECTION

Electrical systems are designed to protect you, the wires, the components, and the devices served by the system.

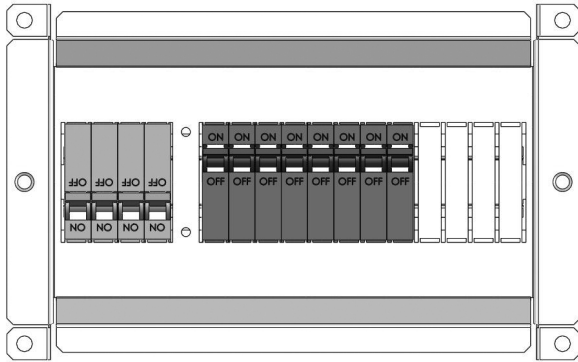

Each FX must be part of a permanently grounded electrical system (see page 8). Grounding protects people and equipment from electrical shock. Grounding must be done according to local and national electrical codes.

Circuit breakers — rated at 100% duty cycle — protect wiring by limiting the amount of current entering a system. All wired electrical systems require circuit breakers or fuses for protection.

OutBack offers both breakers and fuses for over-current protection. If they are provided by other vendors, they must be properly rated.

DC WIRING ORIGINATION

Unit is equipped with DC brass battery terminals with 8M x 1.00 stainless steel threaded studs.

Red terminal=battery positive Black terminal = battery negative Battery terminal covers

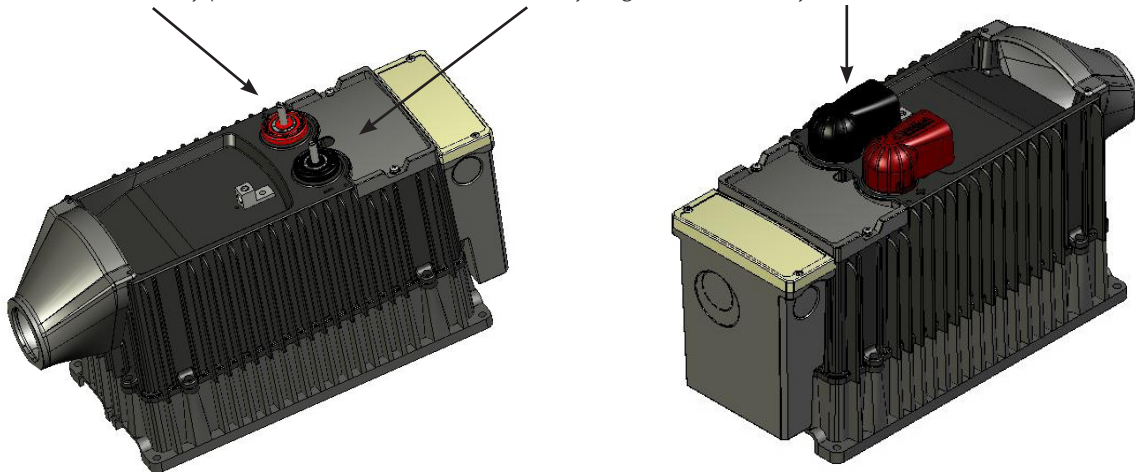

AC WIRING ORIGATION

Lexan cover protects AC Wiring
Compartment Board

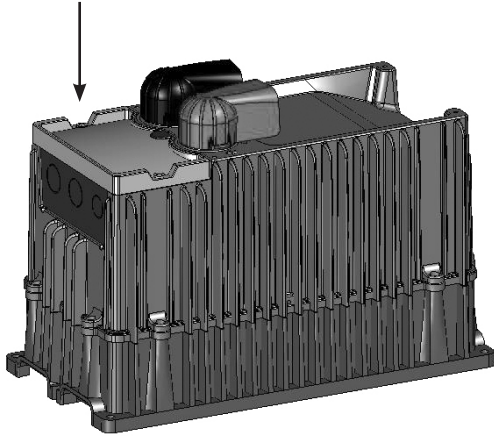

AC Wiring Board

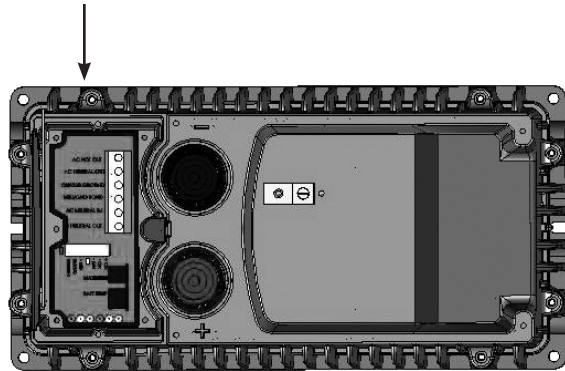

AC WIRING COMPARTMENT BOARD

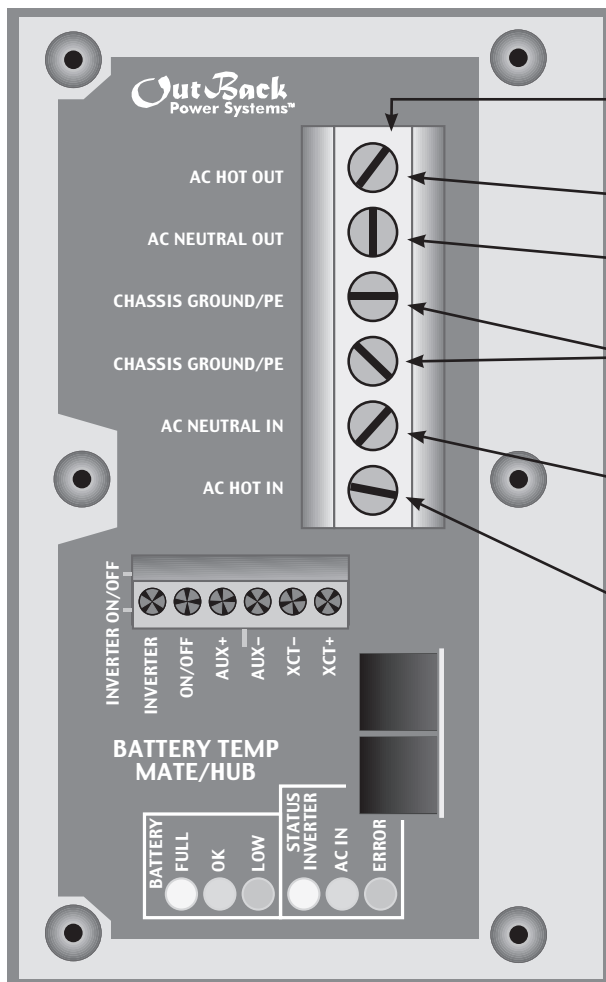

- **AC Terminal Block**--secures AC connections to the FX using set screws
- **AC HOT OUT** supplies power to the loads.
- **AC NEUTRAL OUT** acts as neutral leg for loads supplied by the FX.
- **CHASSIS GROUND** connections are common and act as grounds for both the incoming and outgoing AC circuits.
- **AC NEUTRAL IN** acts as the neutral leg for AC power supplied by either the grid or a generator to the FX.
- **AC HOT IN** connects incoming AC from the grid or a generator to the FX. This AC is used to run loads and recharge batteries.

NOTE: 13.3 mm² (6 AWG) is the largest wire size the AC Wiring Compartment Board can accommodate.

LOW VOLTAGE TERMINALS

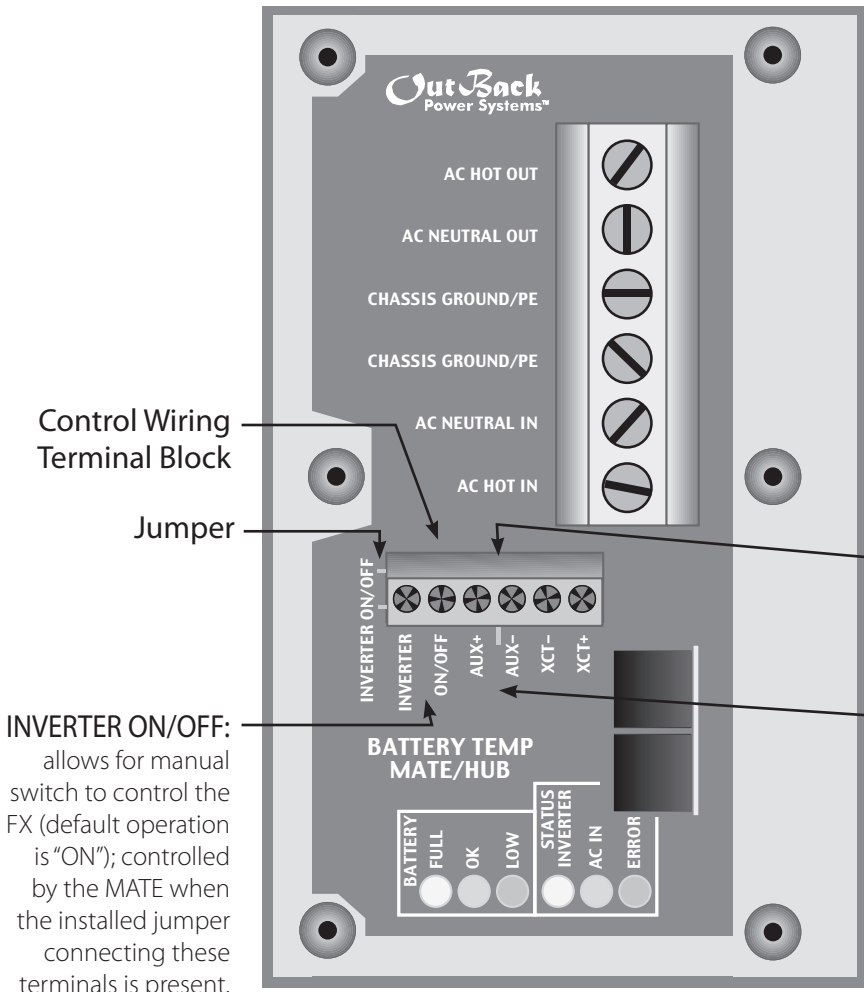

NOTE: Keep Control Wiring Terminal Block screws tight and the block itself secured tightly to AC Board. Otherwise, the FX can malfunction. The Terminal Block can be unplugged for easier wire installation and removal/reinstallation of the FX.

INVERTER ON/OFF: allows for manual switch to control the FX (default operation is "ON"); controlled by the MATE when the installed jumper connecting these terminals is present.

AUX OUTPUT (AUX+/AUX-): 12 Vdc at 0.7 amps (8.4 watts) maximum is available at these terminals; the AUX's default is to drive cooling fans or the Turbo Fan.

XCT+/XCT- are non-operational terminals. Do not connect anything to them.

AC AND DC GROUNDING REQUIREMENTS

- Connect only to a grounded, permanent wiring system. Ensure there is only one neutral-ground connection in the system at any time. Some codes require this connection be made at the main panel only.
- Some generators have their own neutral-ground connection. If a generator is used, its neutral-ground connection will need to be disengaged for proper system operation.
- For all installations, the negative battery conductor should be bonded to the grounding system at one (and only one) point in the system.
- OutBack products are not designed for use in a positive grounded system. Please contact OutBack Technical Support for further information.

The equipment ground on each is marked with this symbol:



Box lug for grounding the FX chassis

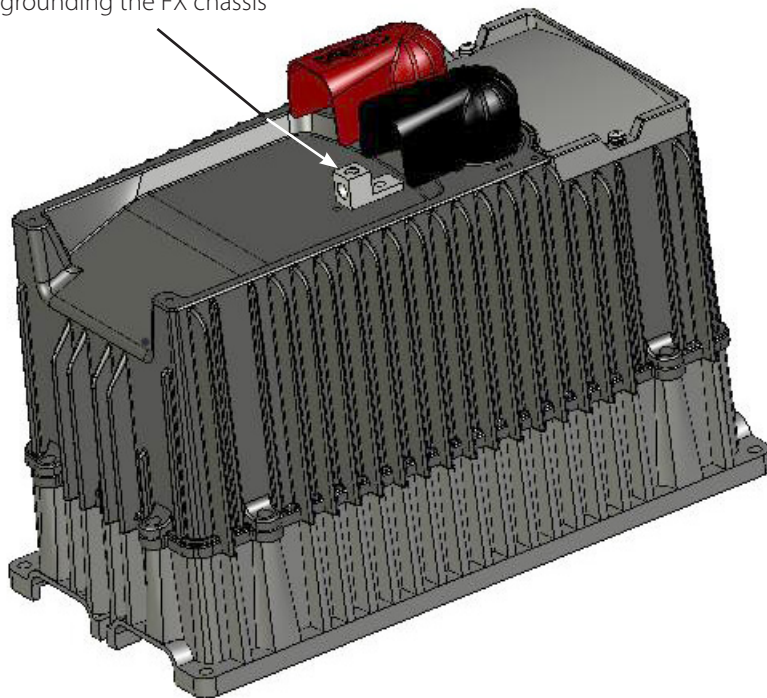

FX PARTS AND ACCESSORIES

AC CONDUIT PLATE

- AC conduit connects to the AC Conduit Plate for installations which do not utilize an optional FW-ACA.

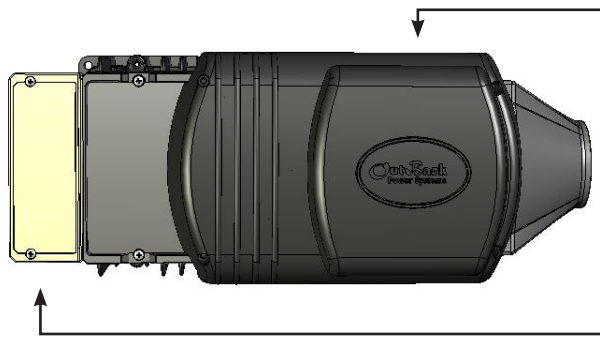
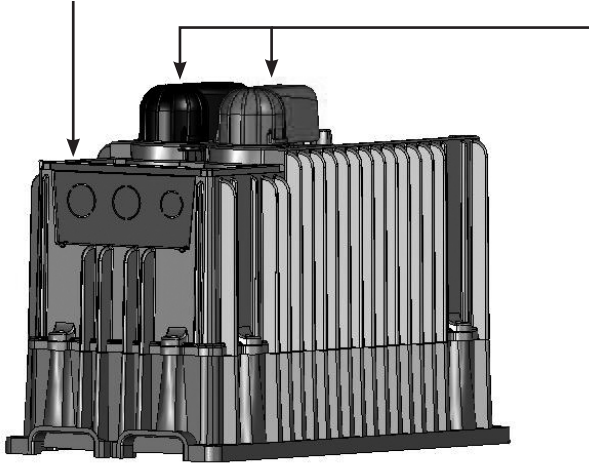

BATTERY TERMINAL COVERS

- The caps are made of stiff plastic with a snap-on design; remove them carefully using a flat-blade screwdriver inserted into the slots on the sides of each cover.
- DC conduit may be required for exposed installations.
- The DCA cover option (see below) allows conduit connection.
- Always keep the battery terminal covers installed.

DCC (DC COMPARTMENT COVER)

- Covers the DC terminal area and provides space to mount other components such as a DC current shunt
- Can be used with or without the DCA
- This is an optional accessory.

FW-ACA (AC CONDUIT ADAPTER)

- Extends the AC wiring compartment
- Connects to OutBack's FLEXware enclosures
- Protects and secures flexible cable with strain relief
- Houses the FLEXware Surge Protector
- Knockouts are intended for cables/strain relief
- This is an optional accessory.

TURBO FAN COVER

- Included in place of a DCC on sealed FXs

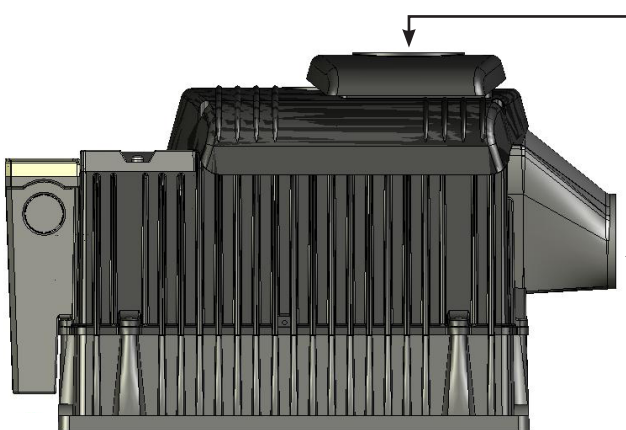

DCA (DC CONDUIT ADAPTER)

- Allows the connection of two-inch TSC (Trade Size Conduit) to the FX
- Connects to OutBack's FLEXware enclosures

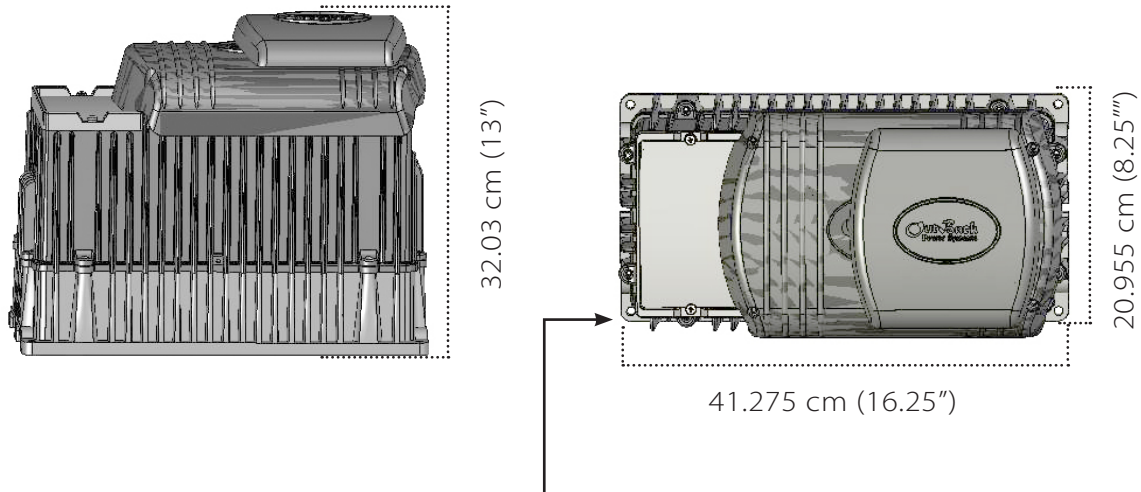

- Insert appropriate fasteners at all four corners of the FX for a secure installation.
- Weight varies from 27.7 - 28.4 kg (61.0 - 62.2 lbs) depending on the model

MOUNTING

- The FX Series Inverter/Charger is approved for indoor or enclosed protected mounting only.
- The FX must be secured with appropriate fasteners to a sturdy mounting surface capable of supporting its weight. It is easier for two people to install the FX due to its weight.
- OutBack FX inverters can be mounted in any position, but they perform better in locations offering plenty of air circulation.
- **NOTE:** If using an OutBack FLEXware Mounting Plate, avoid large air gaps behind the plate which can result in louder mechanical noise during inverting/charging under heavy loads.
- Due to the variance in other mounting methods, OutBack only endorses the use of FLEXware or previous versions of its mounting plate for installing the FX and associated system components using M6 X 20mm machine screws (stainless steel for FLEXware and self-tapping for older mounting plates), one per corner. Follow the instruction manual that comes with each mounting system.
- If mounting the FX on other surfaces such as plywood, wall studs, or masonry, use appropriate fasteners to support approximately its weight. OutBack cannot be responsible for damage to the FX if it is attached with inadequate fasteners.
- Install and secure each FX before attaching any wiring.

WIRE CONNECTIONS

NOTE: A system's individual voltage requirements (230 VAC single phase or 3-phase), as well as how each FX is to function, all determine how the inverters are wired. Each FX must be wired to a specific leg or phase of the system. Each FX must be programmed or "stacked" according to this phase. Please see the STACKED FX SYSTEMS section, beginning on page 25, and the *International Series GTFX and GVFX Grid-Interactive Inverter/Charger Programming Manual*, before connecting any wires to or from the FX inverter.

AC

Follow these steps to wire the FX to your system:

1. Shut all AC breakers off or remove any fuses before connecting any wiring.
2. Shut off all DC breakers, including the PV breakers.
3. With all power off, run lengths of 10.0 mm² (8 AWG) or larger wire between the AC Wiring Compartment Board AC OUT terminals and sufficient overcurrent protection via an AC circuit breaker. This breaker should be sized to protect the wire you are using, but should not exceed the maximum AC input current of the FX model used in the system (see FX product specifications, beginning on page 36). The breaker should be installed inside of a metal chassis such as OutBack's FLEXware series or an existing panel.
4. With the over current protection connected, run lengths of 10.0 mm² (8 AWG) wire between the AC Wiring Compartment Board AC IN terminals and the AC input breaker. The breaker should be installed inside of a metal chassis such as OutBack's FLEXware series or an existing panel. The AC input hot conductor must be supplied through an AC branch-rated circuit breaker from your main electrical panel or source. This breaker should be sized to protect the wire you are using, but should not exceed the maximum AC input current of the FX model used in the system (see FX product specifications, beginning on page 36).

DC

- Use crimped and sealed copper ring terminal lugs with 0.79 cm (5/16") hole or compression-type lug to connect battery cables to DC terminals. Soldered cable lugs are also acceptable.
- Use recommended cable sizes (see page 42) to reduce losses and ensure high performance of FX (smaller cables can reduce performance and possibly damage the unit).
- Keep cables together (e.g., using a tie-wrap) as much as possible.
- Ensure cables pass through the same knockout and conduit fittings. This helps to cancel the effects of self-induction in the cables.

TORQUE REQUIREMENTS

CONNECTION	TORQUE
AC and PV breakers	to 2.48 Nm/22 inch-lbs
DC shunt	to 20.4 Nm/15 foot-lbs
DC battery connections	to 13.6 Nm/10 foot-lbs
FX's DC terminals	to 3.38 Nm/5 foot-lbs
FX's AC terminals	to 3.38 Nm/30 inch-lbs

Table 1 Torque Values for Installation

BATTERY WIRING EXAMPLES

In renewable energy systems, batteries are connected to each other in one of three ways:

- Series (voltage increases, amperage stays the same as a single battery)
- Parallel (voltage stays the same as a single battery, amperage increases)
- Series/Parallel (both voltage and amperage increase)

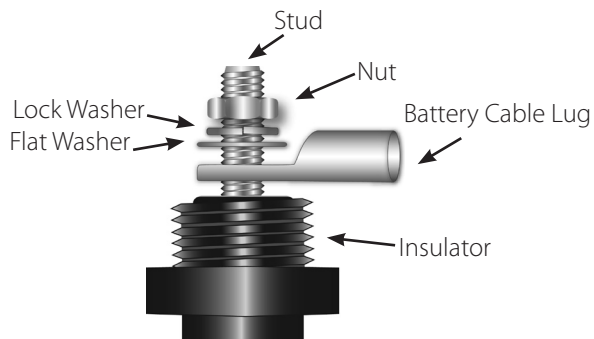
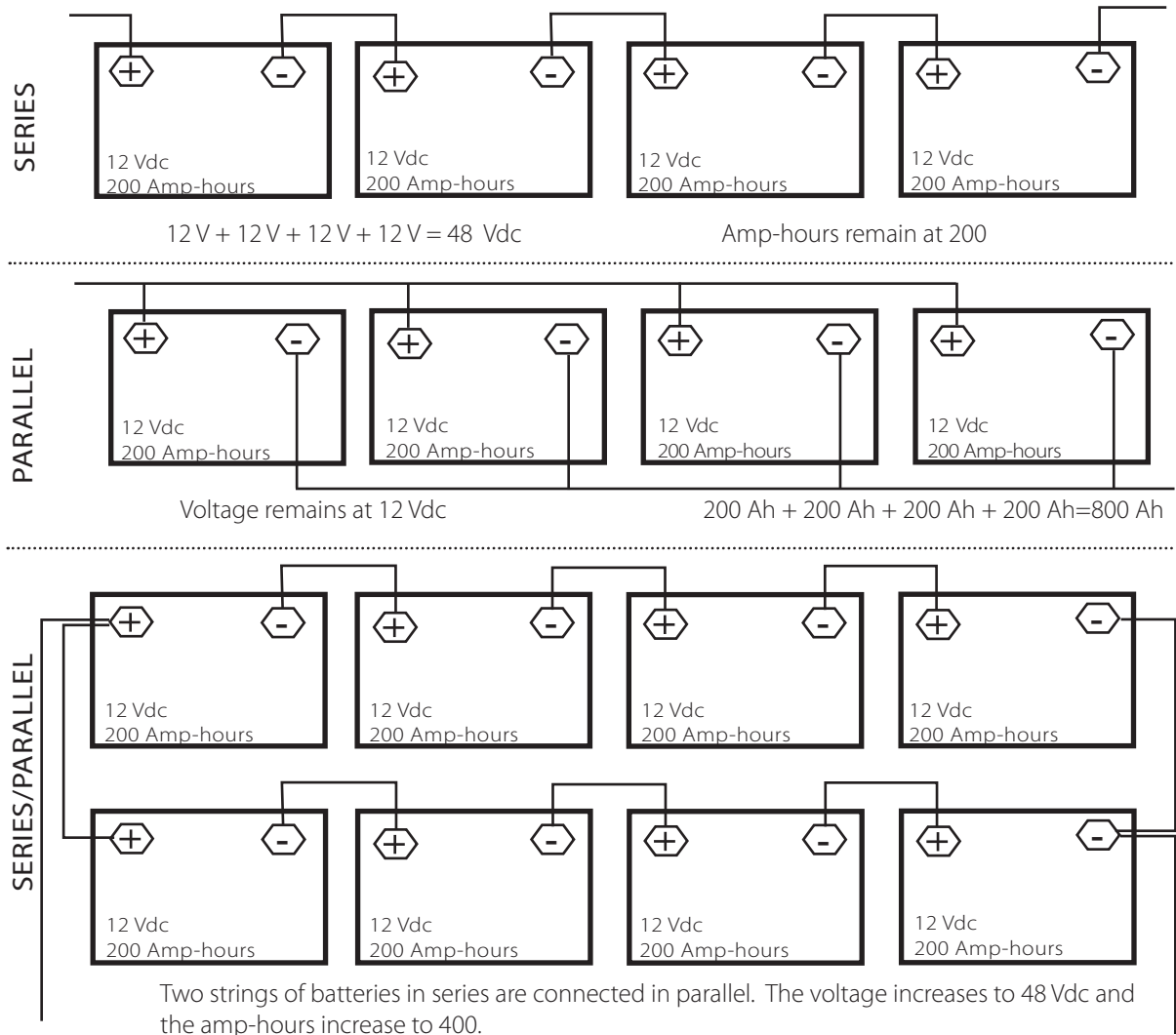

- Never install extra washers between the terminal mounting surface and the battery cable lug—the connection must be direct and secure.
- Always install breakers or fuses within the positive battery cable.
- Torque 67.4 mm^2 (2/0 AWG), 107 mm^2 (4/0 AWG), or larger code-approved cables rated 75°C or higher to 6.77 Nm (60 inch-pounds)

6 Vdc Battery Wiring Examples

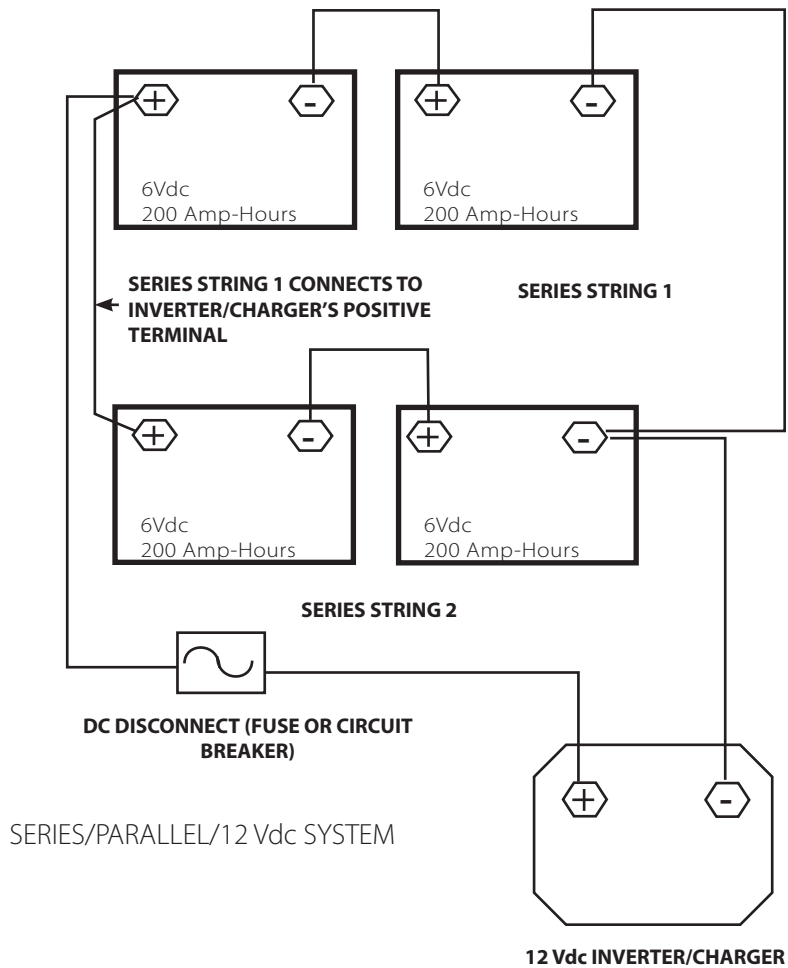
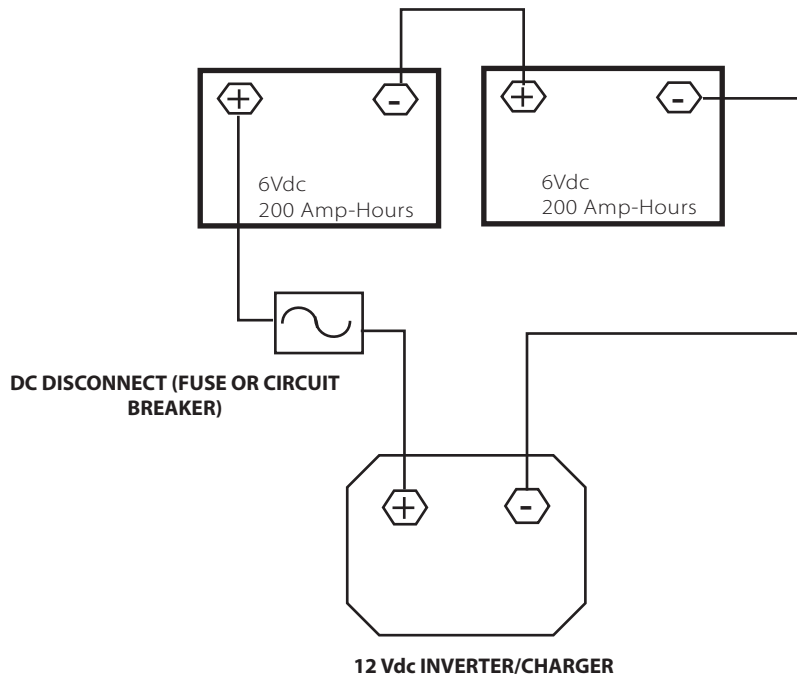

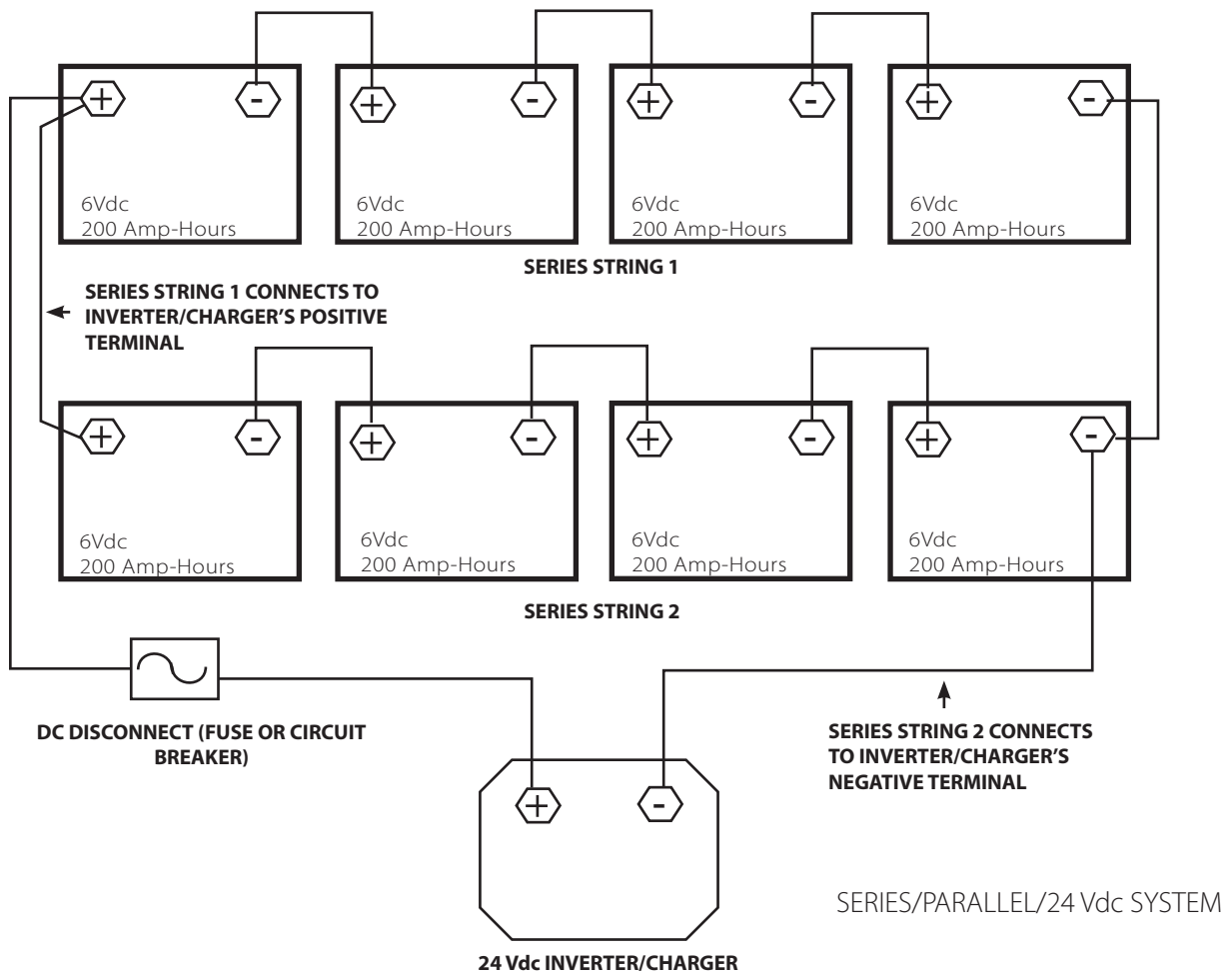
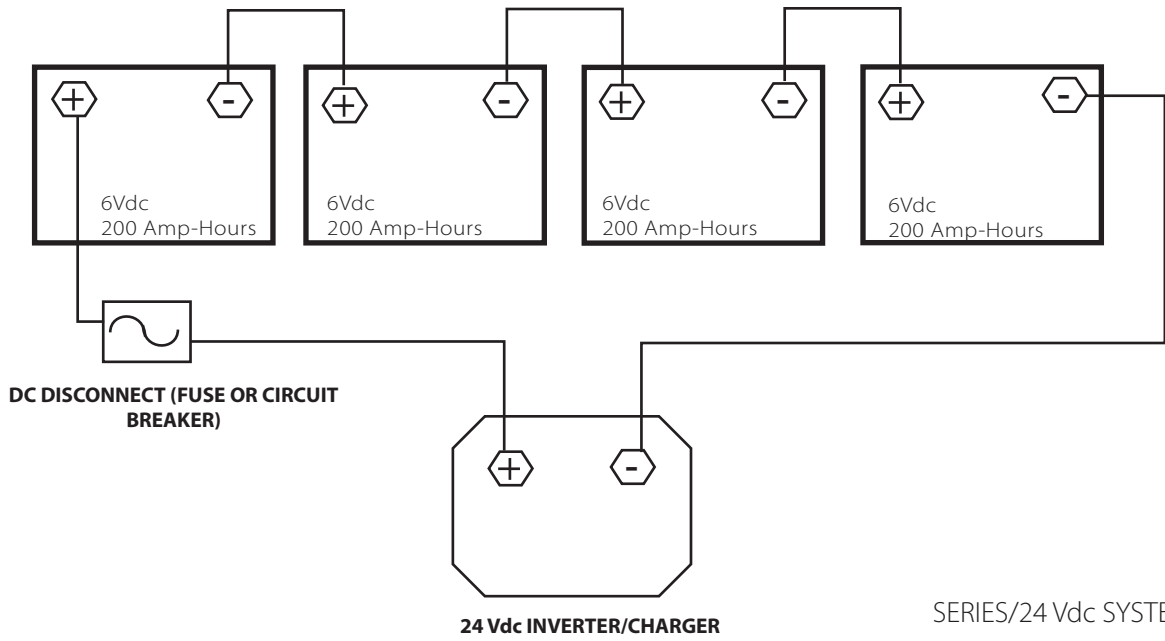

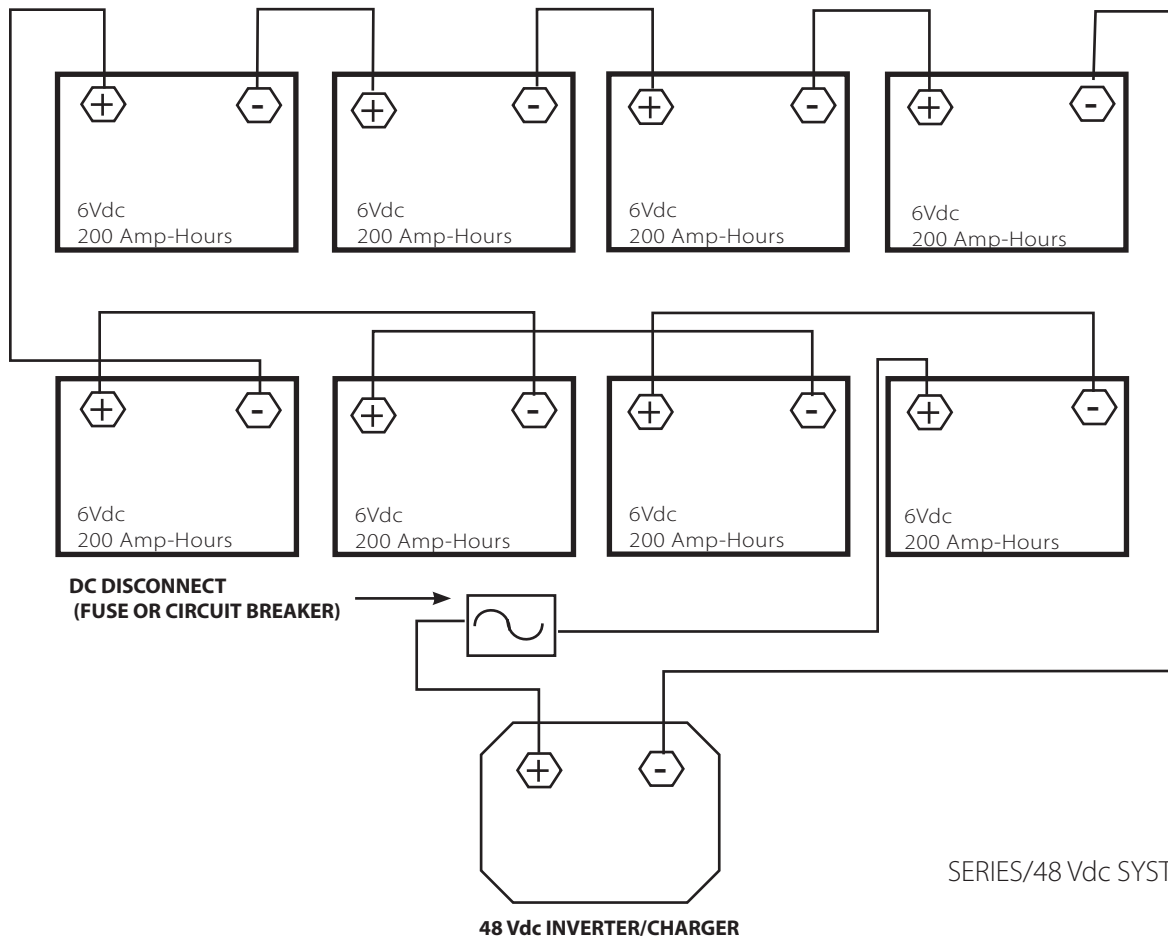

12 Vdc Battery Wiring Examples

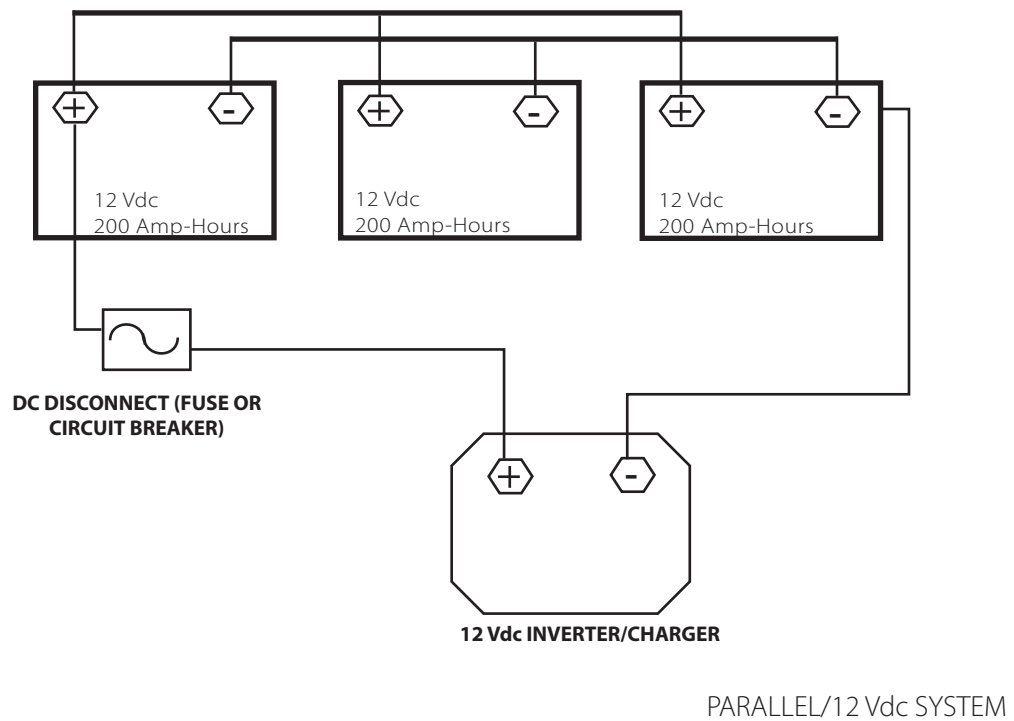
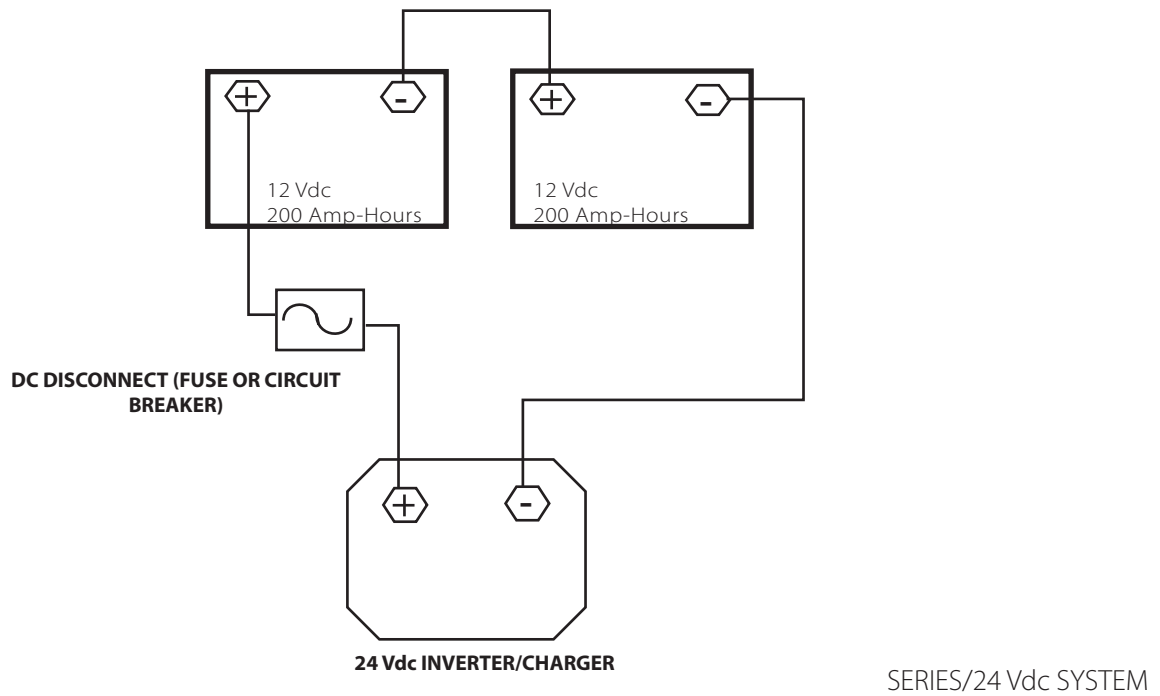

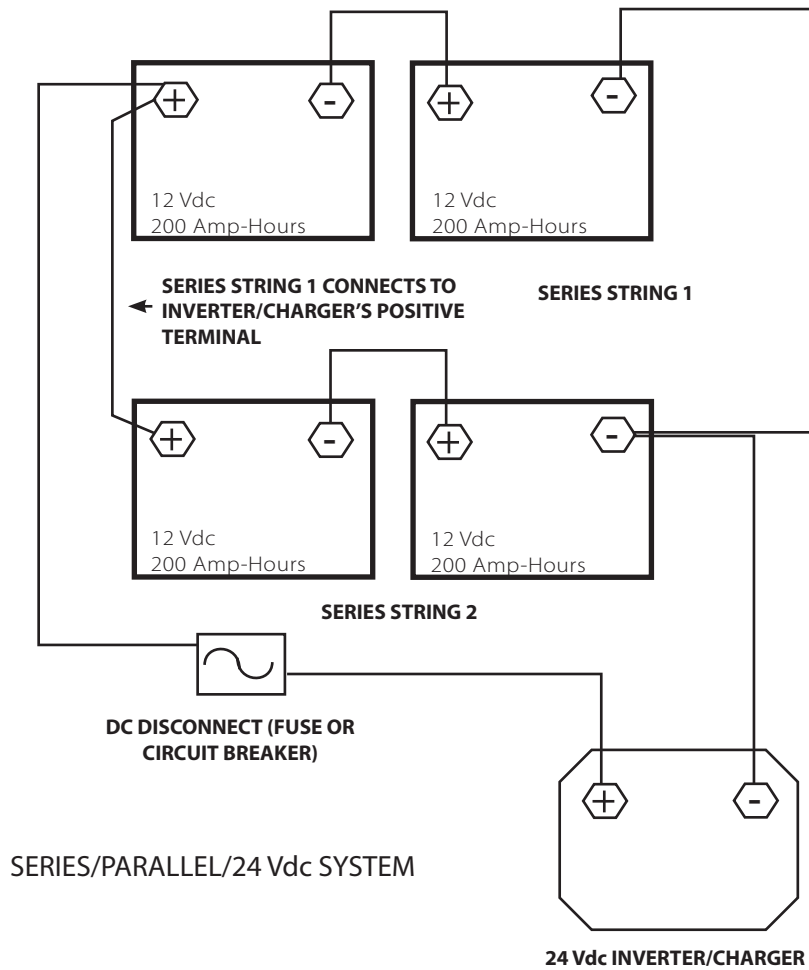
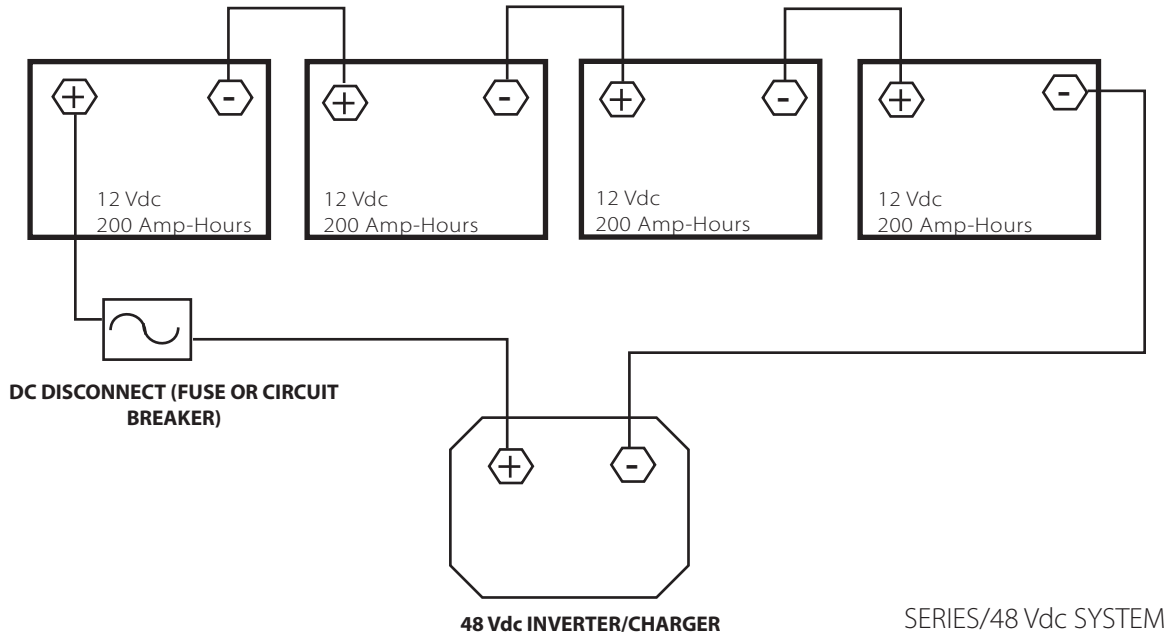

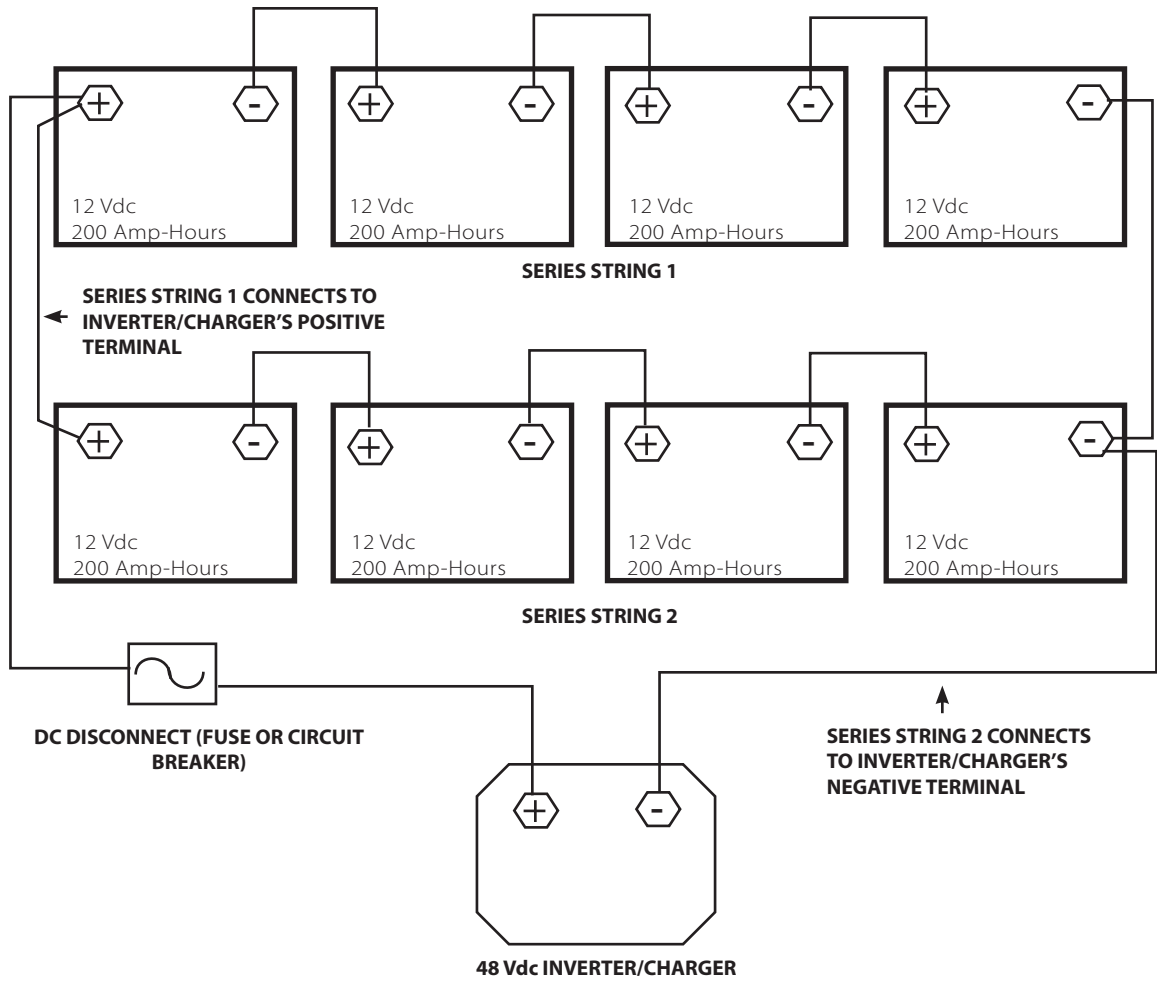

SERIES/PARALLEL/48 Vdc SYSTEM

AC WIRING NOTES

AC HOT OUT

- AC hot output conductor (brown) wire gauge must be sized to the breakers and loads.

AC NEUTRAL OUT/AC NEUTRAL IN

- Both neutral terminals are common with each other within the FX.
- Only one neutral needs to connect at the terminal if a separate common neutral bus bar is installed.

CHASSIS GROUND

- Both CHASSIS GROUND terminals are common within the FX.
- The AC input and AC output ground wires can connect to these terminals, or one ground wire can be connected if a common ground bus bar is installed.

AC HOT IN

- The AC hot input conductor (brown) must be supplied through an appropriately-sized AC branch rated circuit breaker.
- 10.0 mm² (8 AWG) or larger wire is recommended to accommodate the FX's AC transfer relay.

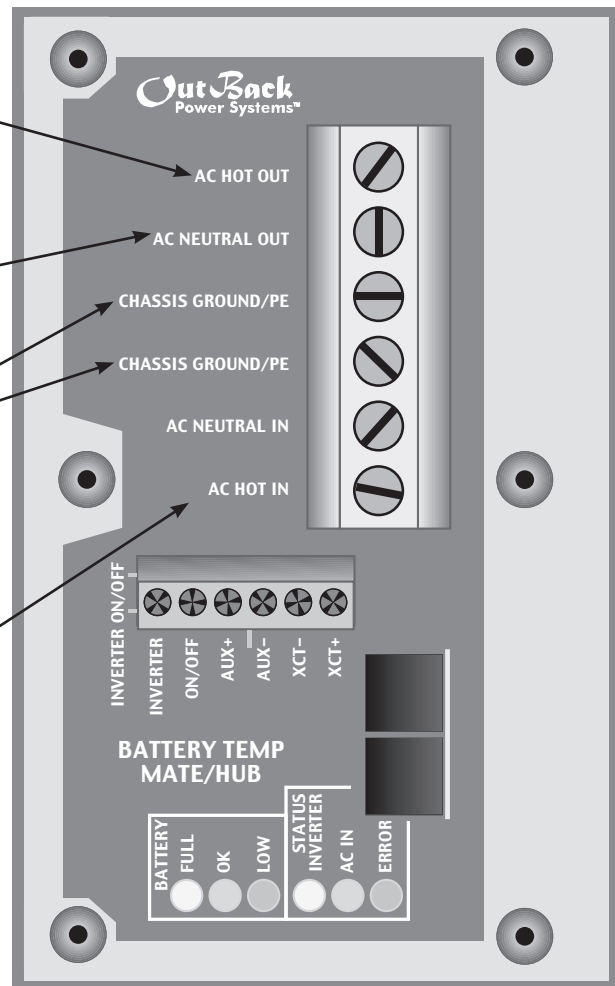

13.3 mm² (6 AWG) is the largest size of wire that can be used with the input or output terminals.

LOW-VOLTAGE WIRING

This six-position terminal block can be unplugged to make wiring easier and to simplify the removal and reinstallation of an FX. It must be securely and completely plugged in for proper FX functioning. Otherwise, operational errors can occur.

Control Wiring Terminal Block

12 Vdc at 0.7 amps (8.4 watts) is available at the AUX+/AUX- terminals

A switch can be wired to the INVERTER and ON/OFF terminals to manually control the FX

XCT+/XCT- are not operational

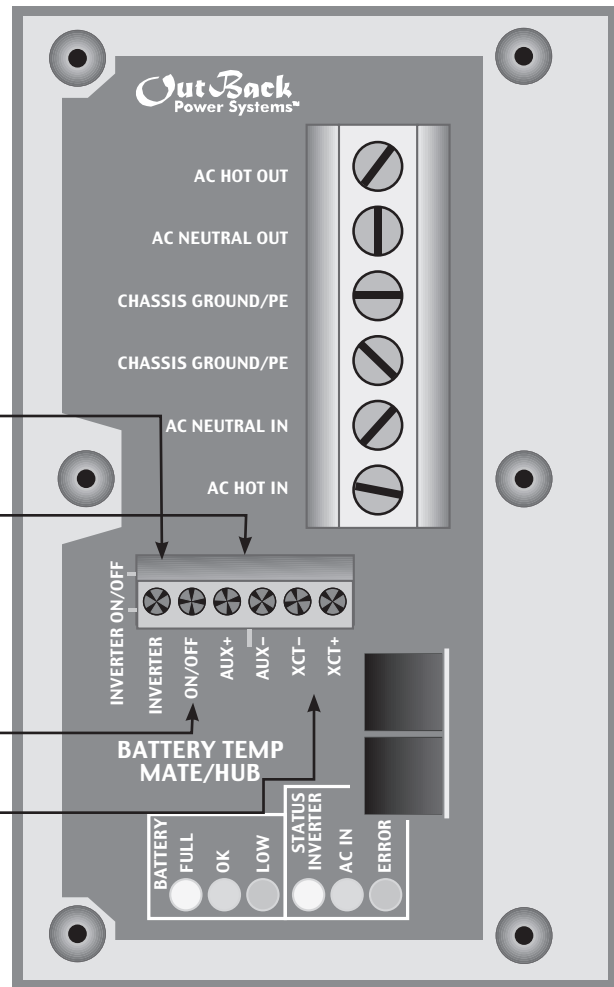

INVERTER and ON/OFF

- You can remove the pre-installed jumper and connect the ON/OFF terminals with a switch. This allows manual control of the FX.
- When a jumper or connection is installed in either of these locations, the inverter will be ON.
- When a switch is installed, the inverter is ON when the switch is closed and OFF when the switch is open.
- Do not remove the jumper when a system is ordered with a MATE. The MATE handles all FX ON/OFF functions.

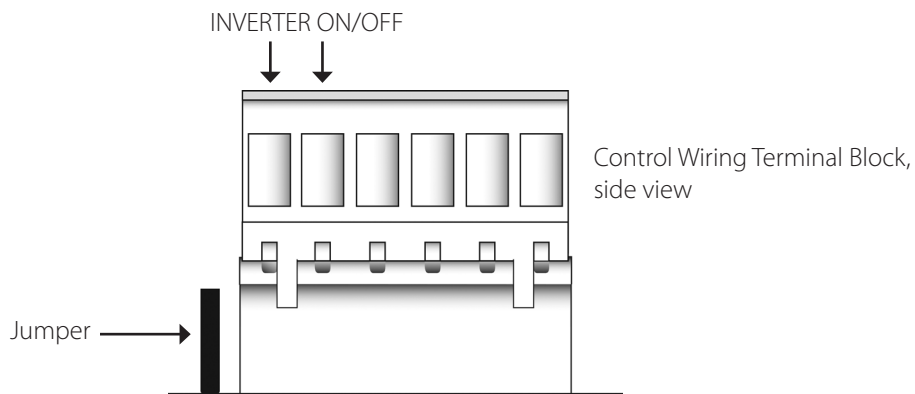



Prior to installing an ON/OFF switch, if the FX's AC output is off, check that the jumper is present and well-connected before installing a switch. You want to confirm the system is in good working order.

Should you decide to install an OutBack MATE at a later date, bear in mind the installed switch overrides the control provided by the MATE if the switch is set to OFF. If the switch is set to ON, the MATE will function normally and control the inverter(s).

AUXILIARY OUTPUT (AUX + / AUX -)

The Auxiliary output system uses the AUX + and AUX – terminals. It is programmed through the MATE to do a variety of tasks:

- The default use for these terminals drives the OutBack FX Turbo Kit or DC12-FAN accessory for external cooling.

NOTE: These terminals should not be connected to any type of DC load greater than 0.7 amps.

- The FX includes internal electronic over-current protection for the AUX 12 Vdc output circuit which auto resets if it is short-circuited. No additional fuses are required.
- For automatic or advanced generator start functions, the Auxiliary Output can drive a 12 Vdc automotive relay for the two-wire starting circuitry of a generator. OutBack recommends a good quality gold-plated relay.

NOTE:

- (1) The FLEXnet DC comes with an internal relay for this use.
- (2) OutBack Power Systems does not support three-wire start generators; however, a three-wire to two-wire conversion kit is available from an electronic control manufacturer such as Atkinson Electronics (www.atkinsonelectronics.com)
- (3) Either the MATE or the FLEXnet DC can be programmed for Auto-Gen Start (please refer to component manuals for more information).

XCT + / XCT -

These terminals are not operational at this time.

RTS, MATE/HUB WIRING

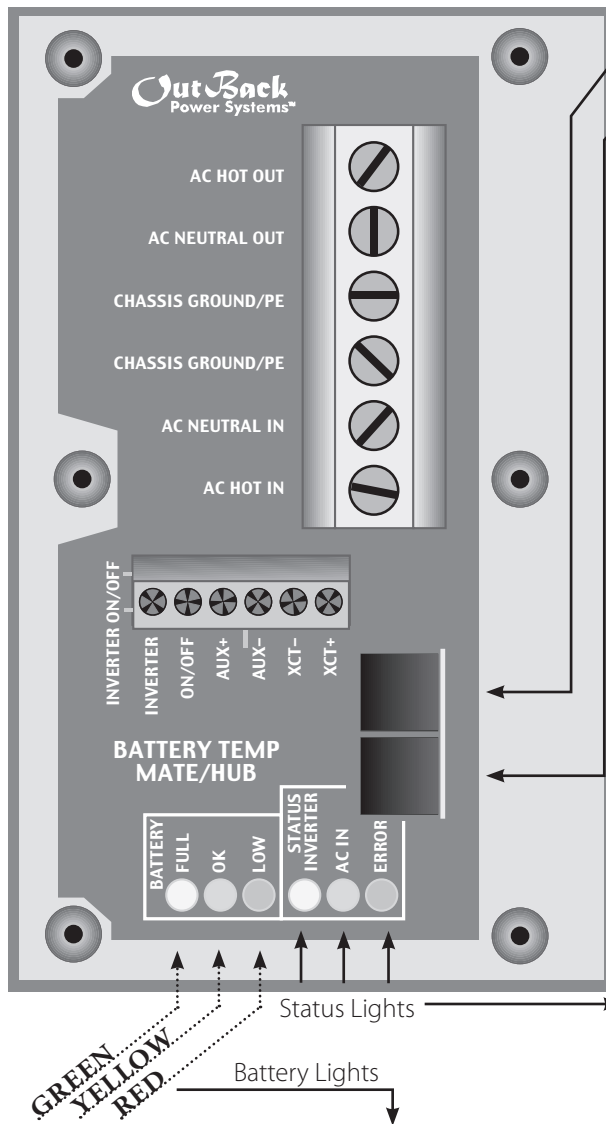

RJ-11 modular jack connects the RTS, the external battery temperature sensor.*

RJ-45 jack connects MATE or HUB to FX using CAT5 cable.**

*When a HUB is used, plug the RTS into the Master FX, which should be connected to the HUB's Port 01. The RTS cable is folded and routed under the AC Wiring Compartment's Lexan cover, fitting into a small indentation in the aluminum casting between the battery terminals. ONLY USE THE OUTBACK RTS; OTHER BRANDS YIELD INCORRECT READINGS.

**If the system has multiple FX inverters and/or OutBack Charge Controllers, a HUB is required.

LED Color	LED Action	LED indicates
GREEN	SOLID GREEN	Inverter ON
	Flashing GREEN	Search mode or Slave power
	Off	Inverter OFF
YELLOW	SOLID YELLOW	AC source is connected
	Flashing YELLOW	AC input live, waiting to connect to FX
	Off	No AC input present
RED	SOLID RED	Critical error, contact OutBack Power Systems
	Flashing RED	Warning, a non-critical error has occurred

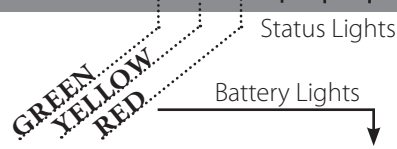

LED Color		12 Vdc	24 Vdc	48 Vdc
GREEN	(FULL)	12.5 or higher	25.0 or higher	50.0 or higher
YELLOW	(OK)	11.5 to 12.5	23.0 to 25.0	46.0-49.6
RED	(LOW)	11.5 or lower	23.0 or lower	46.0 or lower

WARN(ING) Screens

- **acin freq too high:** AC source is above 56 Hz (upper limit) and will be dropped if frequency gets much higher
- **acin freq too low:** AC source is under 44 Hz (lower limit) and will be dropped if frequency gets much lower
- **acin voltage too high:** AC source's voltage is over 270 VAC (default limit) and risks loss of FX connection
- **acin voltage too low:** AC source's voltage is under 207 VAC (default limit) and risks loss of FX connection
- **acin input current exceeds max:** AC loads are drawing more current than the rating of the FX allows
- **temperature sensor fault:** an internal FX temperature sensor is malfunctioning
- **internal comm. error detected:** there is a communication problem between the MATE and the FX
- **internal fan failure detected:** the FX's internal cooling fan is not operating properly
- **airtemp:** displays a numeric value representing the air temperature around the FX*
- **fettemp:** displays a numeric value representing the temperature of the FETs (Field Effect Transistors)*
- **captemp:** displays a numeric value representing the temperature of the ripple capacitors*

*These values are used for troubleshooting purposes. The higher the numerical value, the cooler the temperature.

STACKED FX SYSTEMS

The FX inverter can be used singly, or in a “stacked” system. Stacking refers to interfacing multiple inverters with the OutBack HUB networking accessory. Stacked inverters coordinate their outputs and can produce far more power than a single inverter. Wattage can be combined onto a single-phase bus, or onto a three-phase system.

PARALLEL STACKING

- FX inverters can be stacked in parallel. This will provide the wattage of multiple units on the same 230 Vac bus.
- Up to ten FX inverters can be paralleled. Systems larger than four inverters require the OutBack HUB10 accessory.
- This book gives examples of “parallel dual” and “parallel quad” installations, with two and four units respectively. These systems require the use of the OutBack HUB4. The HUB10 can be used if other devices need to be networked along with the inverters.

THREE-PHASE STACKING

- Three FX inverters can be stacked to supply three-phase power. This will provide the wattage of three units on a 230/400 Vac bus.
- Parallel stacking requires the use of the OutBack HUB4. The HUB10 can be used if other devices need to be networked along with the inverters.

INSTALLATION TYPES

SINGLE FX SYSTEM

- All FX AC wiring must be sized to handle 30 amps AC or more.
- A 30-amp input breaker must be used for all FX models.
- A single FX can continuously power 2.0 kW to 3.0 kW of loads depending on which model is used.

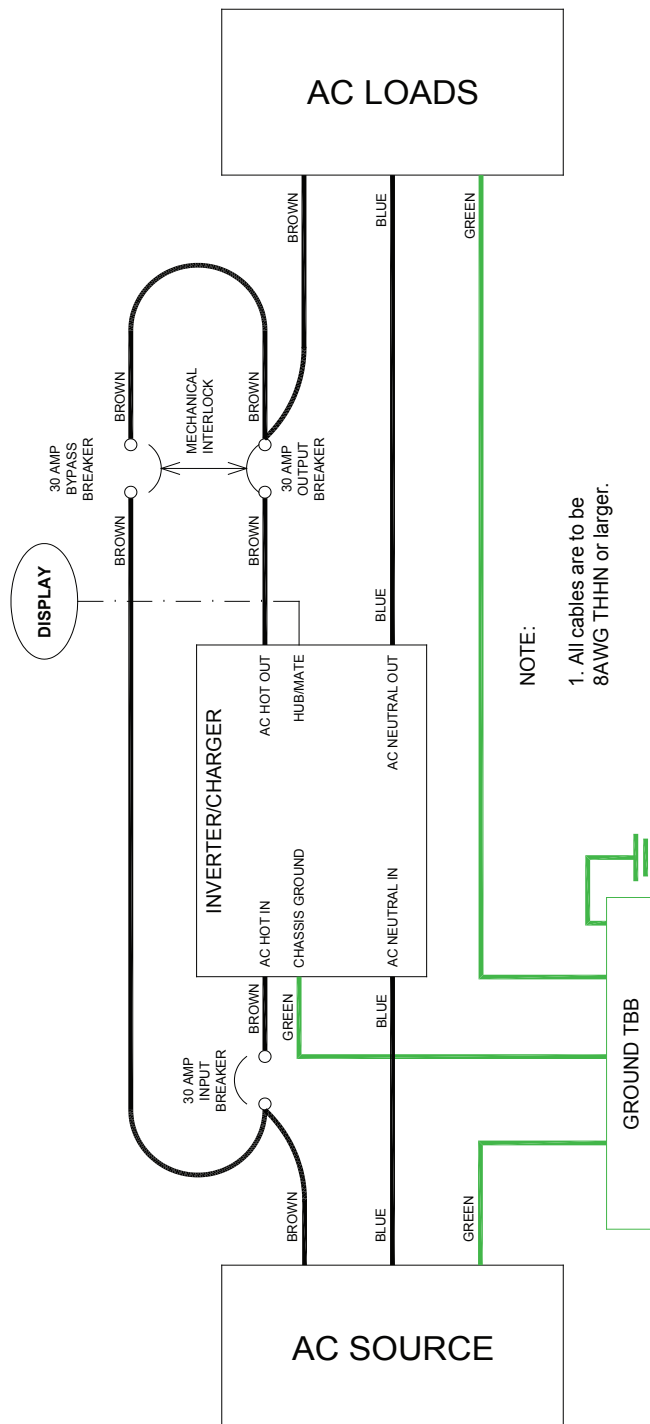

PARALLEL DUAL FX SYSTEM

- All AC wiring from the AC source and to the AC loads must collectively handle 60 amps AC or more.
- All other AC wiring capacity must equal 30 amps AC.
- A paralleled dual FX system can continuously power 4-6 kW of loads depending on which model is used.

NOTE: Program the lowest-installed FX as Master (1-2ph MASTER) and the second FX as an Out-Back L1 Slave (OB SLAVE L1). The Master FX must be plugged into Port 1 of the HUB.

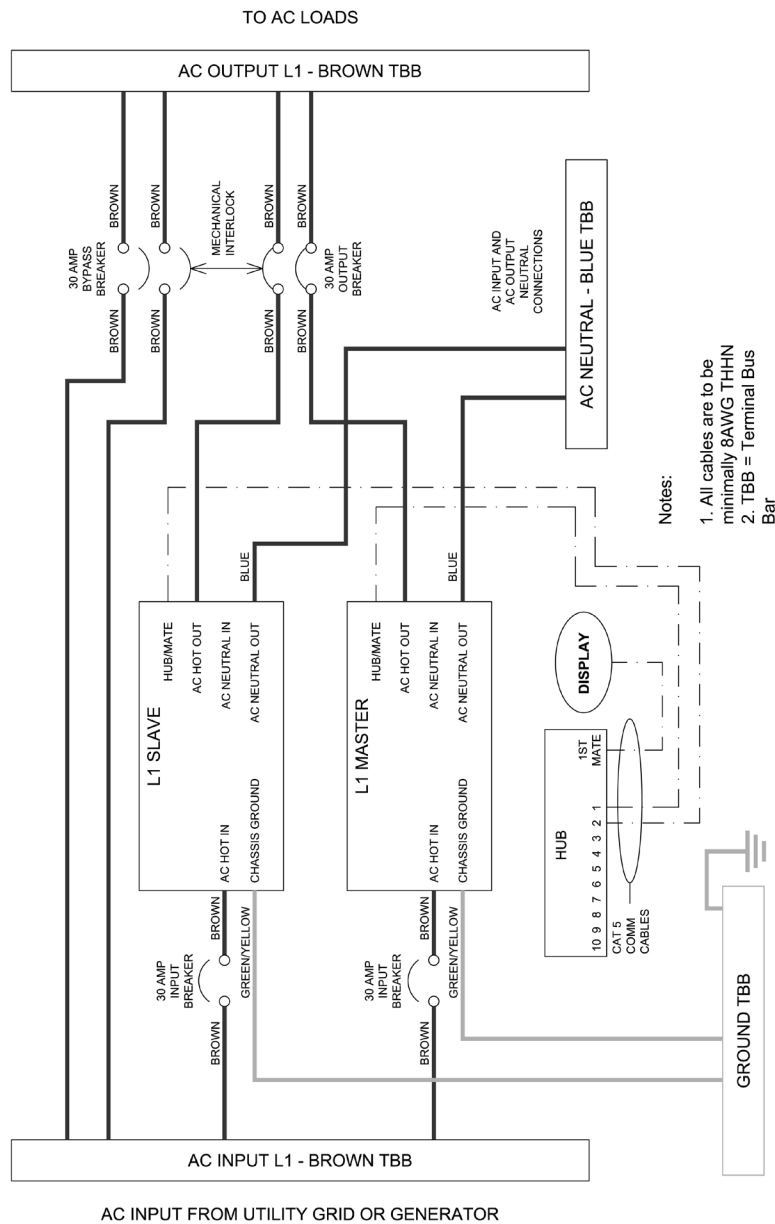

PARALLEL QUAD FX SYSTEM

- All AC wiring from the AC source and to the AC loads must collectively handle 100 amps AC or more.
- All other AC wiring must handle a capacity of 30 amps AC.
- This system can continuously power 8-12 kW of loads depending on which model is used.
- Connecting more load than the continuous rating of the FX may cause breakers to trip or the FX to shut off its AC output.

Parallel Quad System

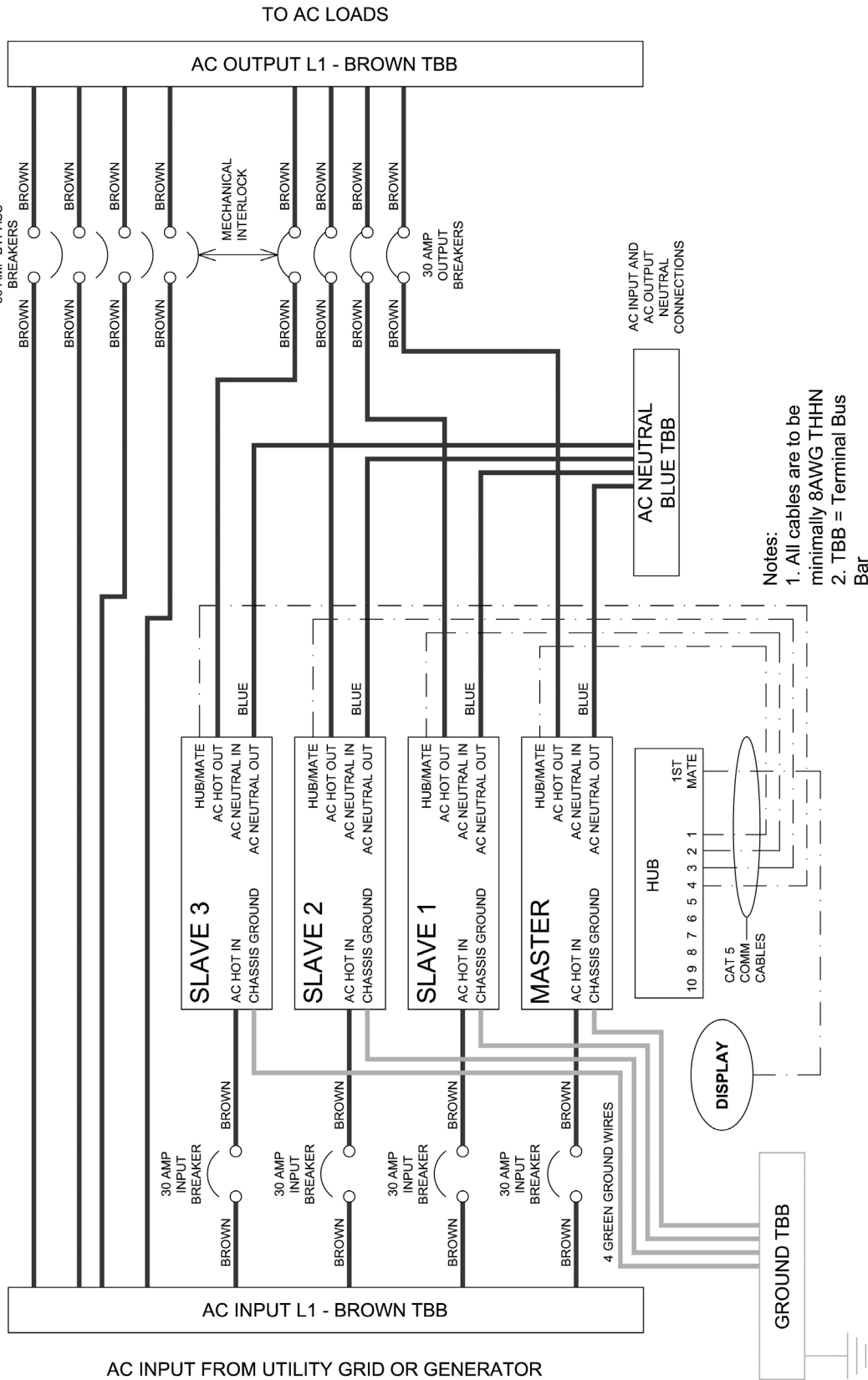

THREE-PHASE FX SYSTEM

- This system produces 230 Vac per phase and 400 Vac from phase to phase.
- All FX AC wiring must be sized to handle 30 amps AC or more.
- This system can power continuously up to 9 kW of loads depending on which model is used.
- Connecting more power than the continuous rating of the FX may cause breakers to trip or the FX to shut off its AC output.
- The jumper in the HUB must be left in the standard position (usually called the “series/parallel” position) for three-phase configuration with International Series grid-tied models. (This instruction is specific for these FX models, and may conflict with the *HUB Installation and User Guide*.)

NOTE: Program the bottom FX as Master and the two upper FXs as 3-phase Slaves (3p Classic B and 3p Classic C). Keep the phases in order: phase one is connected to the FX programmed Master; phase two is connected to 3p Classic B; and phase three to 3p Classic C.

Three-Phase System

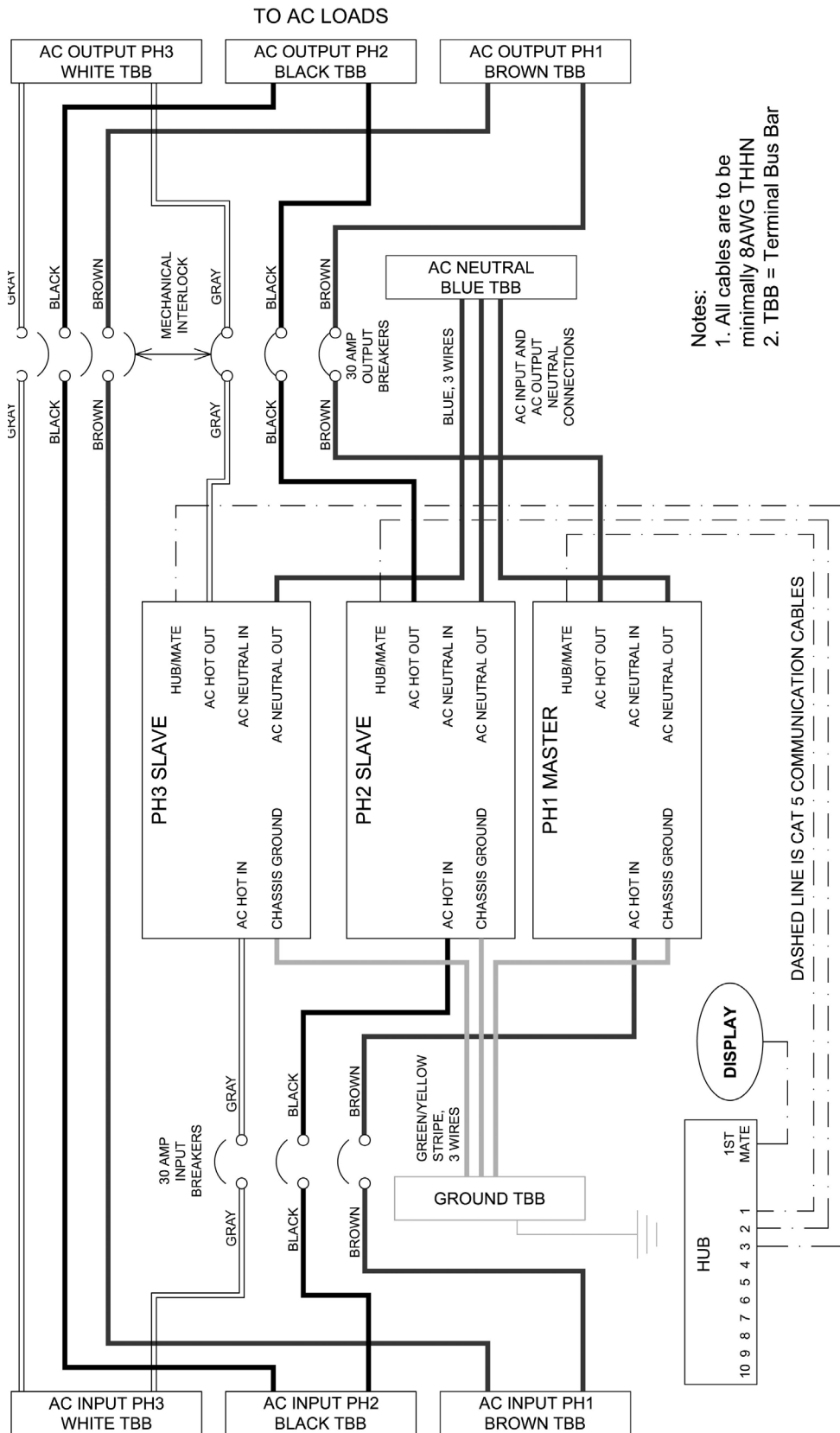

- Notes:
1. All cables are to be minimally 8AWG THHN
 2. TBB = Terminal Bus Bar

THIS PAGE INTENTIONALLY LEFT BLANK

GENERATOR AUTO START

The following schematic shows how to hook up a relay that interfaces with the two-wire start generator. Three-wire start generators require an adapter like the Atkinson GSCM available at www.atkinsonelectronics.com.

TWO WIRE START GENERATOR HOOK UP

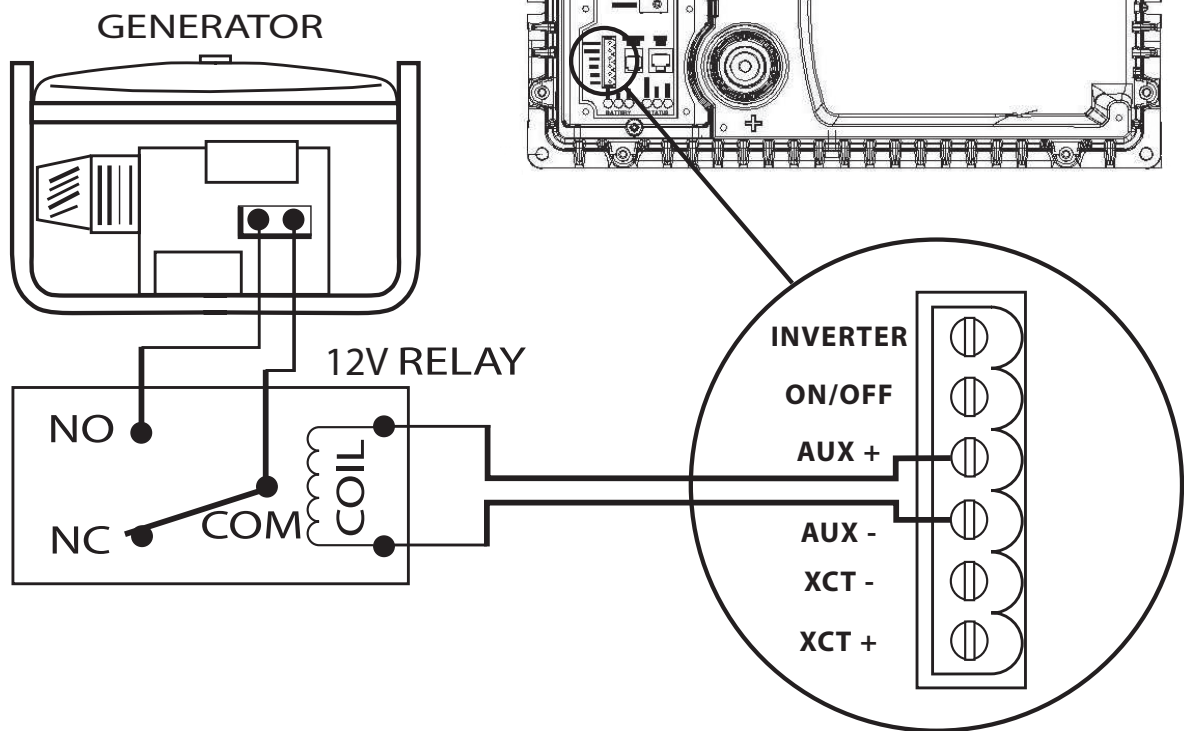

Most 12-volt relays will work for generator starting.
Select one between 2- and 30-amp contacts.

MULTIPLE AC SOURCES WITH THE FX INVERTER

When a system has the option of using either a generator or the utility grid as their AC input:

- Both the AC “Hot” and AC “Neutral” lines must be connected to the appropriate source.
- A connection can be made using a single-pole, double-throw switch (available from electrical component suppliers) which has one connection each for AC hot wire.
- This switch must be rated to handle the system’s maximum AC voltage and AC current.
- The switch must isolate the two input sources from each other. When the switch is thrown, the AC connection to one line must be broken before contacting the other connection. (A common term for this type of switch is “break-before-make”.)
- The neutral lines are common throughout the system. The same applies to the ground wires.
- The electrical system should have neutral and ground bonded together at a single point. This is shown in the lower right corner of the drawing for convenience, but the bonding is usually performed in the main electrical panel.
- If any other neutral-ground bonds are present in the system, particularly in the generator, they must be removed.

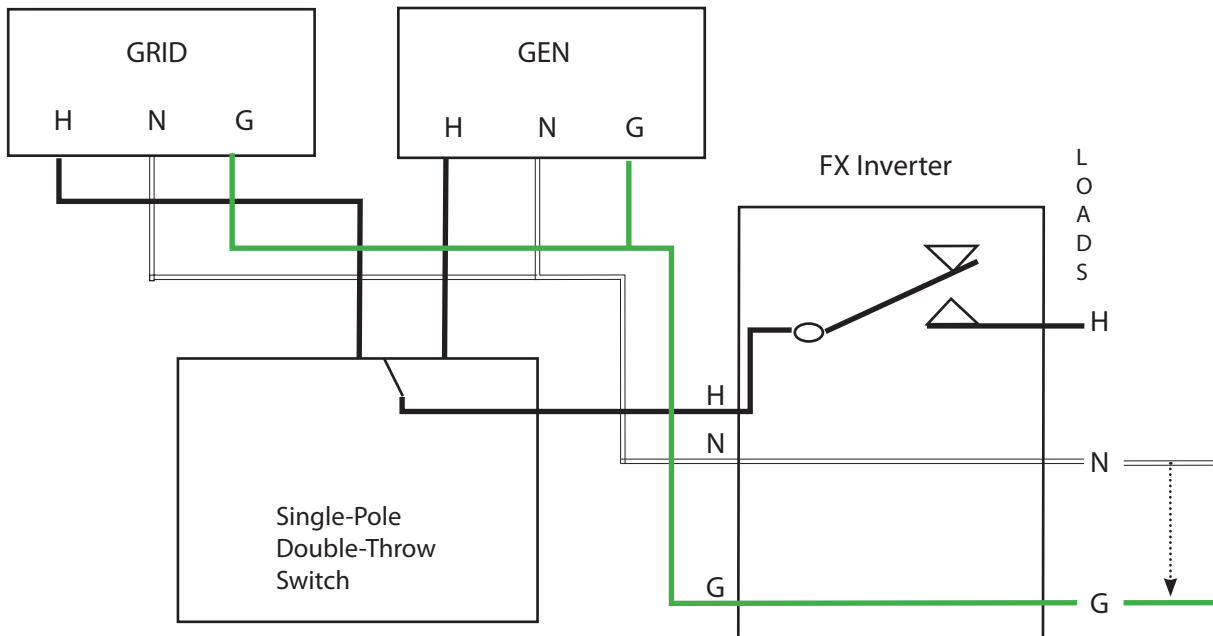

INSTALLATION CHECK LIST

<i>ITEM</i>	<i>YES</i>	<i>NO</i>
All manuals read and reviewed?		
▶ FX		
▶ OutBack Charge Controller		
▶ MATE		
▶ HUB		
System mounted with the recommended number and sized fasteners?		
System installed according to local codes?		
System inspected?		
System permanently grounded?		
Did the installer use OutBack recommended wire type and gauge adjusted for temperature ratings and length?		
▶ All AC wiring rated for 75 °C or higher?		
▶ Battery cables rated 75 °C or higher?		
▶ 10.0 mm ² (8 AWG) wire or larger used for FX AC Hot In and AC Hot Out?		
▶ FX connected with correctly-sized branch-circuit overcurrent protection?		
▶ All cables torqued to OutBack specifications?		
AC and PV breakers to 2.48 Nm/22 inch-lbs?		
All DC connections to 13.55 Nm/10 foot-lbs?		
FX AC terminals to 3.38 Nm/30 inch-lbs?		
FX battery breaker to 5.08 Nm/45 inch-lbs?		
All terminal block screws torqued to 3.38 Nm/2.5 foot-lbs?		

SPECIFICATIONS

GTFX2012E

Nominal DC Input Voltage Range	12 Vdc
Output AC Voltage / Frequency	230 Vac / 50 Hz
Continuous Power Rating at 25 °C Ambient	2000 VA
Continuous AC RMS Output at 25 °C	8.7 amps AC
Idle Power - Full AC Output	≈ 20 watts DC
Idle Power - Search Mode	6 watts DC
Typical Efficiency	90%
Total Harmonic Distortion - Typical	2%
Output Voltage Regulation	± 2%
Maximum Output Current – Peak (1 mSec)	28 amps AC
Maximum Output Current - RMS (100 mSec)	20 amps AC
AC Overload Capability - Surge	4600 VA
AC Overload Capability - 5 Second	4000 VA
AC Overload Capability - 30 Minutes	2500 VA
AC Input Current Maximum	30 Amps AC
AC Input Voltage Range	140 to 280 Vac
AC Input Frequency Range	45.0 to 55.0 Hz
DC Input Range	10.5 to 17.0 Vdc
DC Input Current – Rated Power	200 amps DC
Continuous Battery Charger Output	100 amps DC

GTFX2024E

Nominal DC Input Voltage Range	24 Vdc
Output AC Voltage / Frequency	230 Vac / 50 Hz
Continuous Power Rating at 25 °C Ambient	2000 VA
Continuous AC RMS Output at 25 °C	8.7 amps AC
Idle Power - Full AC Output	≈ 20 watts DC
Idle Power - Search Mode	6 watts DC
Typical Efficiency	92%
Total Harmonic Distortion - Typical	2%
Output Voltage Regulation	± 2%
Maximum Output Current – Peak (1 mSec)	35 amps AC
Maximum Output Current - RMS (100 mSec)	25 amps AC
AC Overload Capability - Surge	5750 VA
AC Overload Capability - 5 Second	4800 VA
AC Overload Capability - 30 Minutes	3100 VA
AC Input Current Maximum	30 amps AC
AC Input Voltage Range	140 to 280 Vac
AC Input Frequency Range	45.0 to 55.0 Hz
DC Input Range	21.0 to 34.0 Vdc
DC Input Current – Rated Power	100 amps DC
Continuous Battery Charger Output	50 amps DC

GTFX2348ET

Nominal DC Input Voltage Range	48 Vdc
Output AC Voltage / Frequency	230 Vac / 50 Hz
Continuous Power Rating at 25 °C Ambient	2300 VA
Continuous AC RMS Output at 25 °C	10.0 amps AC
Idle Power - Full AC Output	≈ 23 watts DC
Idle Power - Search Mode	6 watts DC
Typical Efficiency	92%
Total Harmonic Distortion - Typical	2%
Output Voltage Regulation	± 2%
Maximum Output Current – Peak (1 mSec)	35 amps AC
Maximum Output Current - RMS (100 mSec)	25 amps AC
AC Overload Capability - Surge	5750 VA
AC Overload Capability - 5 Second	4800 VA
AC Overload Capability - 30 Minutes	3100 VA
AC Input Current Maximum	30 Amps AC
AC Input Voltage Range	140 to 280 Vac
AC Input Frequency Range	45.0 to 55.0 Hz
DC Input Range	42.0 to 68.0 Vdc
DC Input Current – Rated Power	57.5 amps DC
Continuous Battery Charger Output	30 amps DC

GVFX2612E

Nominal DC Input Voltage Range	12 Vdc
Output AC Voltage / Frequency	230 Vac / 50 Hz
Continuous Power Rating at 25 °C Ambient	2600 VA
Continuous AC RMS Output at 25 °C	11.3 amps AC
Idle Power - Full AC Output	≈ 20 watts DC
Idle Power - Search Mode	6 watts DC
Typical Efficiency	90%
Total Harmonic Distortion - Typical	2%
Output Voltage Regulation	± 2%
Maximum Output Current - Peak (1 mSec)	28 amps AC
Maximum Output Current - RMS (100 mSec)	20 amps AC
AC Overload Capability - Surge	4600 VA
AC Overload Capability - 5 Second	4000 VA
AC Overload Capability - 30 Minutes	3100 VA
AC Input Current Maximum	30 amps AC
AC Input Voltage Range	140 to 280 Vac
AC Input Frequency Range	45.0 to 55.0 Hz
DC Input Range	10.5 to 17.0 Vdc
DC Input Current – Rated Power	260 amps DC
Continuous Battery Charger Output	120 amps DC

GVFX3024E

Nominal DC Input Voltage Range	24 Vdc
Output AC Voltage / Frequency	230 Vac / 50 Hz
Continuous Power Rating at 25 °C Ambient	3000 VA
Continuous AC RMS Output at 25 °C	13.0 amps AC
Idle Power - Full AC Output	≈ 20 watts DC
Idle Power - Search Mode	6 watts DC
Typical Efficiency	92%
Total Harmonic Distortion - Typical	2%
Output Voltage Regulation	± 2%
Maximum Output Current - Peak (1 mSec)	35 amps AC
Maximum Output Current - RMS (100 mSec)	25 amps AC
AC Overload Capability - Surge	5750 VA
AC Overload Capability - 5 Second	4800 VA
AC Overload Capability - 30 Minutes	3300 VA
AC Input Current Maximum	30 amps AC
AC Input Voltage Range	140 to 280 Vac
AC Input Frequency Range	45.0 to 55.0 Hz
DC Input Range	21.0 to 34.0 Vdc
DC Input Current – Rated Power	150 amps DC
Continuous Battery Charger Output	80 amps DC

GVFX3048E

Nominal DC Input Voltage Range	48 Vdc
Output AC Voltage / Frequency	230 Vac / 50 Hz
Continuous Power Rating at 25 °C Ambient	3000 VA
Continuous AC RMS Output at 25 °C	13.0 amps AC
Idle Power - Full AC Output	≈ 23 watts DC
Idle Power - Search Mode	6 watts DC
Typical Efficiency	93%
Total Harmonic Distortion - Typical	2%
Output Voltage Regulation	± 2%
Maximum Output Current – Peak (1 mSec)	35 amps AC
Maximum Output Current - RMS (100 mSec)	25 amps AC
AC Overload Capability - Surge	5750 VA
AC Overload Capability - 5 Second	4800 VA
AC Overload Capability - 30 Minutes	3300 VA
AC Input Current Maximum	30 amps AC
AC Input Voltage Range	140 to 280 Vac
AC Input Frequency Range	45.0 to 55.0 Hz
DC Input Range	42.0 to 68.0 Vdc
DC Input Current – Rated Power	75 amps DC
Continuous Battery Charger Output	40 amps DC

VOLTAGE, POWER, AND FREQUENCY RANGES

SPECIFIED AC OUTPUT VOLTAGE OF INTERNATIONAL GRID-INTERACTIVE SERIES

Single Inverter	230 Vac at 50 Hz
Parallel Stacked	230 Vac at 50 Hz on one AC output leg
Three-Phase Stacked	230 Vac at 50 Hz per AC output leg (limit three) / 400 Vac at 50 Hz between AC output legs

MAXIMUM CONTINUOUS OUTPUT POWER

An FX Series Inverter/Charger's model number indicates its maximum continuous output power by changing the last two digits to zeros. For instance, a GTFX2024ET has a maximum continuous output power of 2000 VA (volt-amps).

GTFX2012E	2000 VA
GTFX2024E	2000 VA
GTFX2348E	2300 VA
GTFX2612E	2600 VA
GVFX3024E	3000 VA
GVFX3048E	3000 VA

AC INPUT OPERATING VOLTAGE RANGE

NOTE: If the AC input source is out of the range noted below, the FX will not connect or stay connected.
(Vac = volts AC)

All International Series Inverter/Chargers	140 – 280 Vac
--	---------------

AC INPUT FREQUENCY RANGE

NOTE: If the AC input source is out of the range noted below, the FX will not connect or stay connected.

All International Series Inverter/Chargers	44 - 56 Hz
--	------------

DC RECOMMENDED VOLTAGE RANGE

NOTE: The last two digits in the model number designate the nominal DC voltage.
Example: GVFX3648E = 48 Vdc. (Vdc = volts DC)

12 Vdc Systems	11 – 16 Vdc
24 Vdc Systems	22 – 32 Vdc
48 Vdc Systems	44 – 64 Vdc

CURRENT RANGES

MAXIMUM AC OUTPUT CURRENT

This is the amount of surge current that the FX will quickly supply for a split second. Depending on the surge, the FX can be overloaded for a minimum time of 5 seconds to a maximum time of 30 minutes.

All International Series Inverter/Chargers	35 Aac per FX for 1 millisecond
--	---------------------------------

MAXIMUM AC INPUT CURRENT

An AC input source will supply power for two separate FX AC circuits: the AC transfer switch and the battery charger. The AC transfer switch transfers the AC input power to the AC loads. The FX's battery charger will "back off" if the total AC loads—including the charger—exceed the AC input current limit. (Default setting is 28 amps AC, or Aac.) This "Input Limit" can be adjusted using the MATE to avoid overloading a generator or a circuit breaker.

All International Series Inverter/Chargers	30 Aac per FX
--	---------------

MAXIMUM CURRENT FOR BATTERY CHARGER

Due to heating, the FX limits AC current drawn to charge the battery. (This setting can be adjusted.) The battery charger has an efficiency in excess of 80%. Other factors, such as cable loss, might reduce efficiency.

MAXIMUM AND DEFAULT AC INPUT AND DC (bulk stage) OUTPUT VALUES

GTFX2012E	AC Max = 6 Aac (Default = 5 Aac)	DC Max = 100 Adc
GTFX2024E	AC Max = 6 Aac (Default = 5 Aac)	DC Max = 50 Adc
GTFX2348E	AC Max = 6 Aac (Default = 5 Aac)	DC Max = 35 Adc
GVFX2612E	AC Max = 6 Aac (Default = 5 Aac)	DC Max = 120 Adc
GVFX3024E	AC Max = 9 Aac (Default = 9 Aac)	DC Max = 80 Adc
GVFX3048E	AC Max = 9 Aac (Default = 9 Aac)	DC Max = 40 Adc

MAXIMUM DC INPUT CURRENT

NOTE: This is the maximum DC current the FX will draw from the battery when starting very large AC loads. (Adc = amps DC) It is not used for sizing the DC disconnect or selecting DC cable gauge. It is used to select the minimum reasonable battery capacity.

12 Vdc FX inverters	600 Adc per FX
24 Vdc FX inverters	300 Adc per FX
48 Vdc FX inverters	150 Adc per FX

RATED DC INPUT CURRENT

NOTE: This is the maximum continuous DC current that the FX will draw from the batteries when inverting.

GTFX2012E	200 Adc
GTFX2024E	100 Adc
GTFX2348E	57.5 Adc
GTFX2612E	260 Adc
GVFX3024E	150 Adc
GVFX3048E	75 Adc

RECOMMENDED DC BREAKER AND CABLE SIZES

Inverter Model	Rated DC Input	DC Breaker (OutBack model)	Recommended Cable Size (maximum one-way length 3 m or 10')
GTFX2012E	200 Adc	OBDC-250	107 mm ² (4/0 AWG)
GTFX2024E	100 Adc	OBDC-175	67.4 mm ² (2/0 AWG)
GTFX2348E	57.5 Adc	OBDC-100	53.4 mm ² (1/0 AWG)
GVFX2612E	200 Adc	OBDC-250	107 mm ² (4/0 AWG)
GVFX3024E	150 Adc	OBDC-250	107 mm ² (4/0 AWG)
GVFX3048E	75 Adc	OBDC-125	53.4 mm ² (1/0 AWG)

MAINTENANCE

If damaged or malfunctioning, the FX should be repaired by a qualified user, installer, or service center following OutBack Power Systems' instructions and guidelines. Please contact your energy dealer for assistance. Incorrect repairs and/or reassembly risks malfunction, electric shock or fire.

For routine, user-approved maintenance:

- Disconnect all circuit breakers and related electrical connections before doing any cleaning or adjustments.
- Solar modules may produce hazardous voltages when exposed to light; cover them with opaque material before servicing any connected equipment or service at night.
- If a remote or automatic generator start system is used, disable the automatic circuit and/or disconnect the generator from its starting battery while servicing. This will prevent accidental starting or operation.

FX Default Values (subject to change with FX upgrades)

12 Vdc System	DEFAULT	MINIMUM	MAXIMUM
Charger			
Float Voltage	13.6 Vdc	12 Vdc	15 Vdc
Absorb Voltage	14.4 Vdc	13 Vdc	16 Vdc
EQ Voltage	14.6 Vdc	14 Vdc	17 Vdc
ReFloat	12.5 Vdc	12 Vdc	13 Vdc
LBCO	10.5 Vdc	9 Vdc	12 Vdc
LBCI	12.5 Vdc	10 Vdc	14 Vdc
Absorb Time	1.0 hours	0.0 hours	24.0 hours
EQ Time	1.0 hours	0.0 hours	24.0 hours
Float Time	1.0 hours	0.0 hours	24.0 hours
Charger OFF/AUTO/ON	AUTO	N/A	N/A
Sell RE	13 Vdc	10 Vdc	15 Vdc
GenAlert & AUX			
GenAlert Off Set Point	14 Vdc	12 Vdc	18 Vdc
GenAlert On Set Point	11 Vdc	10 Vdc	14 Vdc
GenAlert On Delay	4 min	0 min	240 min
GenAlert Off Delay	9 min	0 min	240 min
AUX Output Option	COOL FAN	N/A	N/A
Set AUX Control	AUTO	N/A	N/A
Vent Fan Off Delay	5 min	0 min	30 min
Load Shed Off Set Point	11 Vdc	10 Vdc	14 Vdc
Vent Fan On Set Point	13 Vdc	10 Vdc	16 Vdc
Diversion On Set Point	14.6 Vdc	12 Vdc	16 Vdc
AC Output			
Set Vac	230 Vac	210 Vac	250 Vac
AC Transfer			
AC1/Grid Transfer Delay	6 AC cycles	0 AC cycles	240 AC cycles
Grid Lower Limit	208 Vac	140 Vac	220 Vac
Grid Upper Limit	252 Vac	250 Vac	280 Vac
AC2/Gen Transfer Delay	6 AC cycles	0 AC cycles	240 AC cycles
Gen Lower Limit	208 Vac	140 Vac	220 Vac
Gen Upper Limit	252 Vac	250 Vac	280 Vac
Stacking & Search			
Stacking Phase	Master	N/A	N/A
Search Threshold	6 watts	0 watts	50 watts
Search Pulses	8	4	20
Search Pulse Spacing	60 AC cycles	4 AC cycles	120 AC cycles
Charge Rates & Input			
Vented Model Charge Rate	7 Aac	0 Aac	8 Aac
Sealed Model Charge Rate	6 Aac	0 Aac	7 Aac
Grid Input Limit	30 Aac	2.5 Aac	30 Aac
Gen Input Limit	30 Aac	2.5 Aac	30 Aac
Input Select	Grid	N/A	N/A

24 Vdc System	DEFAULT	MINIMUM	MAXIMUM
Charger			
Float Voltage	27.2 Vdc	24 Vdc	30 Vdc
Absorb Voltage	28.8 Vdc	26 Vdc	32 Vdc
EQ Voltage	29.2 Vdc	28 Vdc	34 Vdc
ReFloat	25 Vdc	24 Vdc	26 Vdc
LBCO	21 Vdc	18 Vdc	24 Vdc
LBCI	25 Vdc	20 Vdc	28 Vdc
Absorb Time	1.0 hours	0.0 hours	24.0 hours
EQ Time	1.0 hours	0.0 hours	24.0 hours
Float Time	1.0 hours	0.0 hours	24.0 hours
Charger OFF/AUTO/ON	AUTO	N/A	N/A
Sell RE	26 Vdc	20 Vdc	30 Vdc
GenAlert & AUX			
GenAlert Off Set Point	28 Vdc	24 Vdc	36 Vdc
GenAlert On Set Point	22 Vdc	20 Vdc	28 Vdc
GenAlert On Delay	4 min	0 min	240 min
GenAlert Off Delay	9 min	0 min	240 min
AUX Output Option	COOL FAN	N/A	N/A
Set AUX Control	AUTO	N/A	N/A
Vent Fan Off Delay	5 min	0 min	30 min
Load Shed Off Set Point	22 Vdc	20 Vdc	28 Vdc
Vent Fan On Set Point	26 Vdc	20 Vdc	32 Vdc
Diversion On Set Point	29.2 Vdc	24 Vdc	32 Vdc
AC Output			
Set Vac	230 Vac	210 Vac	250 Vac
AC Transfer			
AC1/Grid Transfer Delay	6 AC cycles	0 AC cycles	240 AC cycles
Grid Lower Limit	208 Vac	140 Vac	220 Vac
Grid Upper Limit	252 Vac	250 Vac	280 Vac
AC2/Gen Transfer Delay	6 AC cycles	0 AC cycles	240 AC cycles
Gen Lower Limit	208 Vac	140 Vac	220 Vac
Gen Upper Limit	252 Vac	250 Vac	280 Vac
Stacking & Search			
Stacking Phase	Master	N/A	N/A
Search Threshold	6 watts	0 watts	50 watts
Search Pulses	8	4	20
Search Pulse Spacing	60 AC cycles	4 AC cycles	120 AC cycles
Charge Rates & Input			
Vented Model Charge Rate	9 Aac	0 Aac	10 Aac
Sealed Model Charge Rate	7 Aac	0 Aac	8 Aac
Grid Input Limit	30 Aac	2.5 Aac	30 Aac
Gen Input Limit	30 Aac	2.5 Aac	30 Aac
Input Select	Grid	N/A	N/A

48 Vdc System	DEFAULT	MINIMUM	MAXIMUM
Charger			
Float Voltage	54.4 Vdc	48 Vdc	600 Vdc
Absorb Voltage	57.6 Vdc	52 Vdc	64 Vdc
EQ Voltage	58.4 Vdc	56 Vdc	68 Vdc
ReFloat	50 Vdc	48 Vdc	52 Vdc
LBCO	42 Vdc	36 Vdc	48 Vdc
LBCI	50 Vdc	40 Vdc	56 Vdc
Absorb Time	1.0 hours	0.0 hours	24.0 hours
EQ Time	1.0 hours	0.0 hours	24.0 hours
Float Time	1.0 hours	0.0 hours	24.0 hours
Charger OFF/AUTO/ON	AUTO	N/A	N/A
Sell RE	52 Vdc	40 Vdc	60 Vdc
GenAlert & AUX			
GenAlert Off Set Point	56 Vdc	48 Vdc	72 Vdc
GenAlert On Set Point	44 Vdc	40 Vdc	56 Vdc
GenAlert On Delay	4 min	0 min	240 min
GenAlert Off Delay	9 min	0 min	240 min
AUX Output Option	COOL FAN	N/A	N/A
Set AUX Control	AUTO	N/A	N/A
Vent Fan OFF Delay	5 min	0 min	30 min
Load Shed Off Set Point	44 Vdc	40 Vdc	56 Vdc
Vent Fan On Set Point	52 Vdc	40 Vdc	64 Vdc
Diversion On Set Point	58.4 Vdc	48 Vdc	64 Vdc
AC Output			
Set Vac	230 Vac	210 Vac	250 Vac
AC Transfer			
AC1/Grid Transfer Delay	6 AC cycles	0 AC cycles	240 AC cycles
Grid Lower Limit	208 Vac	140 Vac	220 Vac
Grid Upper Limit	252 Vac	250 Vac	280 Vac
AC2/Gen Transfer Delay	6 AC cycles	0 AC cycles	240 AC cycles
Gen Lower Limit	208 Vac	140 Vac	220 Vac
Gen Upper Limit	252 Vac	250 Vac	280 Vac
Stacking & Search			
Stacking Phase	Master	N/A	N/A
Search Threshold	6 watts	0 watts	50 watts
Search Pulses	8	4	20
Search Pulse Spacing	60 AC cycles	4 AC cycles	120 AC cycles
Charge Rates & Input			
Vented Model Charge Rate	9 Aac	0 Aac	10 Aac
Sealed Model Charge Rate	7 Aac	0 Aac	8 Aac
Grid Input Limit	30 Aac	2.5 Aac	30 Aac
Gen Input Limit	30 Aac	2.5 Aac	30 Aac
Input Select	Grid	N/A	N/A

COMPARATIVE WIRE SIZES

The following chart contains information on wire sizes, the DC resistance of the wires and the corresponding diameters and areas of these wires. This information can be used to calculate the voltage drop of the wires or to find an equivalent wire size.

SIZE	DC (AWG) Resistance in Ohms (1000 feet)	CROSS-SECTIONAL AREA	
		INCHES	MILLIMETERS
14	3.14	0.0032	2.08
12	1.98	0.0051	3.31
10	1.24	0.0082	5.26
8	0.78	0.0130	8.37
6	0.50	0.0206	13.30
4	0.31	0.0328	21.15
2	0.19	0.0521	33.62
1	0.15	0.0657	42.41
1/0	0.12	0.0829	53.50
2/0	0.10	0.1045	67.43
3/0	0.08	0.1318	85.01
4/0	0.06	0.1662	107.20

AWG Wire Sizes

NOTE: These sizes represent the conductor only without any insulation.

NOTE: These illustrations may not be to scale and are for example purposes only.

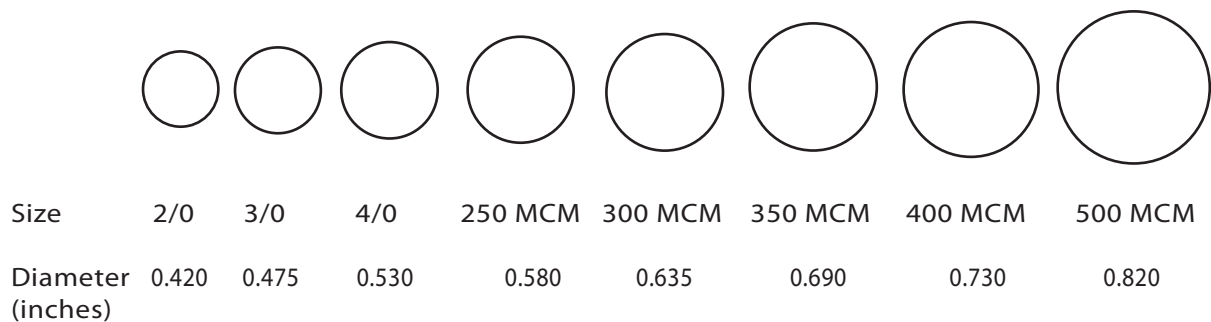
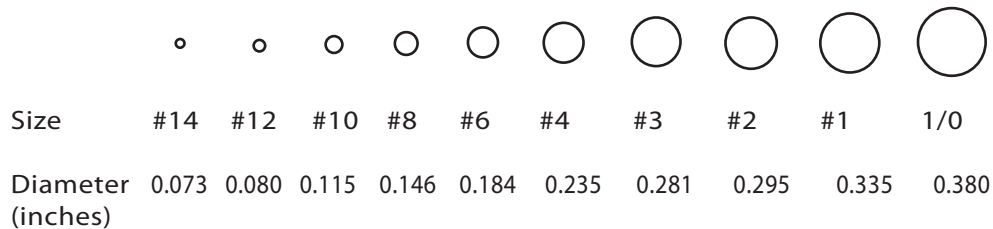



5-Year Limited Warranty for International Series GTFX and GVFX Inverter Products

OutBack Power Systems, Inc. ("OutBack") provides a five-year (5) limited warranty ("Warranty") against defects in materials and workmanship for its International Series GTFX and GVFX Inverter products ("Product").

The term of this Warranty begins on the Product(s) date of manufacture or the initial purchase date as indicated on the warranty registration card submitted to OutBack, whichever is later. This Warranty applies to the original OutBack Product purchaser, and is transferable only if the Product remains installed in the original use location. The warranty does not apply to any Product or Product part that has been modified or damaged by the following:

- Installation or Removal;
- Alteration or Disassembly;
- Normal Wear and Tear;
- Accident or Abuse;
- Corrosion;
- Lightning;
- Repair or service provided by an unauthorized repair facility;
- Operation contrary to manufacturer product instructions;
- Fire, Floods or Acts of God;
- Shipping or Transportation;
- Incidental or consequential damage caused by other components of the power system;
- Any product whose serial number has been altered, defaced or removed; or
- Any other event not foreseeable by OutBack.

OutBack's liability for any defective Product, or any Product part, shall be limited to the repair or replacement of the Product, at OutBack's discretion. OutBack does not warrant or guarantee workmanship performed by any person or firm installing its Products. This Warranty does not cover the costs of installation, removal, shipping (except as described below), or reinstallation of Products or parts of Products.

THIS LIMITED WARRANTY IS THE EXCLUSIVE WARRANTY APPLICABLE TO OUTBACK PRODUCTS. OUTBACK EXPRESSLY DISCLAIMS ANY OTHER EXPRESS OR IMPLIED WARRANTIES OF ITS PRODUCTS, INCLUDING BUT NOT LIMITED TO ANY IMPLIED WARRANTIES OF MERCHANTABILITY OR FITNESS FOR A PARTICULAR PURPOSE. OUTBACK ALSO EXPRESSLY LIMITS ITS LIABILITY IN THE EVENT OF A PRODUCT DEFECT TO REPAIR OR REPLACEMENT IN ACCORDANCE WITH THE TERMS OF THIS LIMITED WARRANTY AND EXCLUDES ALL LIABILITY FOR INCIDENTAL OR CONSEQUENTIAL DAMAGES, INCLUDING WITHOUT LIMITATION ANY LIABILITY FOR PRODUCTS NOT BEING AVAILABLE FOR USE OR LOST REVENUES OR PROFITS, EVEN IF IT IS MADE AWARE OF SUCH POTENTIAL DAMAGES. IF YOU ARE A CONSUMER THAT PURCHASED THIS PRODUCT IN A MEMBER STATE OF THE EUROPEAN UNION, YOU MAY HAVE ADDITIONAL STATUTORY RIGHTS UNDER DIRECTIVE 1999/44/EC. THESE RIGHTS MAY VARY FROM EU MEMBER STATE TO EU MEMBER STATE. SOME STATES (OR JURISDICTIONS) MAY NOT ALLOW THE EXCLUSION OR LIMITATION OF WARRANTIES OR DAMAGES, SO THE ABOVE EXCLUSIONS OR LIMITATIONS MAY NOT APPLY TO YOU.

How to Arrange for Warranty Service

During the warranty period beginning on the invoice date, OutBack Power Systems will repair or replace products covered under this limited warranty that are returned to OutBack Power Systems' facility or to an OutBack Power Systems authorized repair facility, or that are repaired on site by an OutBack Power Systems authorized repair person.

For full Warranty description, see previous page.

Contacting OutBack

To request warranty service, the customer must contact OutBack Technical Support at **+1.360.618.4363**, or **support@outbackpower.com**. To ensure warranty coverage, this contact must be within the effective warranty period. If service is required, the OutBack Technical Support representative will issue a Return Material Authorization (RMA) number.

Troubleshooting

In the event of a Product failure, the customer will need to work with an OutBack Technical Support representative to perform the necessary troubleshooting. This is a required step before a return can be performed. Internal troubleshooting requires a qualified technician to be present at the site of the Product, with a quality voltmeter that measures both DC and AC. The OutBack representative will request voltmeter readings, Product error messages, and other information. The vast majority of problems can be resolved on-site. If the customer does not provide these readings (or cannot visit the site), and the Product is found to have no problems upon return, OutBack may choose to charge additional labor and handling fees up to \$180.00 USD.

Return Material Authorization (RMA)

A request for an RMA number requires all of the following information:

1. Product model and serial number;
2. Proof-of-purchase in the form of a copy of the original Product purchase invoice or receipt confirming the Product model number and serial number;
3. Description of the problem; and
4. Shipping address for the repaired or replacement equipment.

Upon receiving this information, the OutBack representative can issue an RMA number.

Returning Product to OutBack

After receiving the RMA number, the customer must pack the Product(s) authorized for return, along with a copy of the original purchase invoice and warranty certificate, in the original Product shipping container(s) or packaging providing equivalent or reasonable protection. The RMA number must be written on the outside of the packaging where it is clearly visible.

The Product(s) must be shipped back to OutBack Power Systems in their original or equivalent packaging, to the following address:

OutBack Power Systems

RMA # _____

6115 192nd Street NE

Arlington, WA 98223 USA

The customer must insure the shipment, or accept the risk of loss or damage during shipment. If a shipping box is needed for return of a Product, OutBack will, upon request, send a shipping box.

IMPORTANT: OutBack is not responsible for shipping damage caused by improperly packaged Products, the repairs this damage might require, or the costs of these repairs.

If, upon receipt of the Product, OutBack determines the Product or Product part is defective and that the defect is covered under the terms of this Warranty, OutBack will then, and only then, ship a repaired or replacement Product or Product part to the purchaser freight prepaid, non-expedited, using a carrier of OutBack's choice, where applicable.

If Product fails in ninety (90) or fewer days from original purchase date, OutBack will replace with a new Product. If Product fails after ninety (90) days and up to expiration of warranty, OutBack will, at its discretion, either repair and return a Product, or ship a replacement Product. OutBack will determine whether a Product is to be repaired or replaced in accordance with Product age and model. OutBack will authorize advance shipment of a replacement based on Product age and model.

In cases where an OutBack dealer or distributor replaces a Product more than ninety (90) days old with a new Product, OutBack will NOT compensate that dealer or distributor with new stock unless the exchange was authorized in advance by OutBack.

Out of Warranty

If Product is out of warranty, OutBack will repair and return Product for a fee. Alternately, if applicable, upon request, OutBack will advance-ship replacement parts for a fee.

If a shipping box is needed for return of out-of-warranty Product, OutBack will, upon request, send a shipping box. The customer is responsible for paying shipping to OutBack.

The warranty period of any repaired or replacement Product or Product part is ninety (90) days from the date of shipment from OutBack, or the remainder of the initial warranty term, whichever is greater.

This Warranty is void for any Product that has been modified by the customer without authorization by OutBack. A Product with a voided warranty will be treated the same as one with an expired warranty.

THIS PAGE INTENTIONALLY LEFT BLANK



Product Registration

Your purchase of an OutBack Power Systems product is an important investment. Registering our products will help us maintain the standard of excellence you expect from us in terms of performance, quality and reliability.

Please take a moment to register and provide us with some important information.

Name:	E-mail:
Address:	Sold by:
City:	Installer:
State:	Purchase date:
Postal (ZIP) Code:	Model #:

Check all that apply:

<input type="checkbox"/> Off-Grid Installation	Country of Location:
<input type="checkbox"/> On-Grid (Utility Connected) Installation	
<input type="checkbox"/> Residential Installation	
<input type="checkbox"/> Commercial Installation	
Battery Bank Size:	Battery Type:
PV Array Size:	
Generator Type:	

Remove this page from the manual and mail it to:

OutBack Power Systems
 Attn: Product Registration
 19009 62nd Avenue NE
 Arlington, WA USA

THIS PAGE INTENTIONALLY LEFT BLANK

THIS PAGE INTENTIONALLY LEFT BLANK



Corporate Office
19009 62nd Avenue NE
Arlington, WA USA
1.360.435.6030

European Sales Office
+34.93.654.9568

www.outbackpower.com

900-0101-01-00 REV A